

# Maintenance and Operating Instructions

## Large-area sprinkler

Type: VP3 VAC

PERROT



# Contents

<b>1. GENERAL.....</b>	<b>3</b>
<b>2. SAFETY.....</b>	<b>3</b>
2.1. USE OF SYMBOLS IN THESE OPERATING INSTRUCTIONS .....	3
2.2. PROPER USE .....	4
2.3. CLEARLY IMPROPER USE.....	4
2.4. SAFETY INFORMATION.....	4
2.5. DANGERS OF FAILING TO OBSERVE SAFETY INSTRUCTIONS .....	4
<b>3. DESCRIPTION .....</b>	<b>5</b>
3.1 VIEW FROM ABOVE.....	5
3.2 SIDE VIEW.....	5
3.3 SPECIAL TOOLS.....	6
<b>4. TECHNICAL DATA .....</b>	<b>6</b>
<b>5. ASSEMBLY, SET-UP AND INSTALLATION.....</b>	<b>7</b>
5.1 HAZARD WARNINGS.....	7
5.2 INSTALLATION INSTRUCTIONS.....	7
5.3 VP3 POP-UP SPRINKLER INSTALLATION DIAGRAM.....	8
5.4 CABLE BOX IS ON THE SIDE OF THE IRRIGATED AREA.5.4 INSTALLATION SCHEME FOR VP3 WITH RUBBER INFILL LAWN.....	9
5.4.1 HANDLING THE VP3 POP-UP SPRINKLER WITH FILLED SYNTHETIC TURF .....	11
5.4.2 OPERATING INSTRUCTIONS FOR VP3 POP-UP SPRINKLER WITH FILLED SYNTHETIC TURF.....	11
5.5 EXTERNAL START USING KEY SWITCH .....	12
5.6 CABELING .....	12
<b>6. COMMISSIONING AND OPERATION .....</b>	<b>15</b>
6.1 POTENTIAL DANGER .....	15
6.2 COMMISSIONING .....	16
6.3 SETTING THE SECTOR.....	18
6.4 FULL-CIRCLE IRRIGATION .....	19
6.5 REGULATING THE SPEED.....	20
<b>7. DECOMMISSIONING AND PREPARING FOR WINTER .....</b>	<b>21</b>
7.1 PREPARING FOR WINTER.....	21
7.2 SPRINGTIME COMMISSIONING .....	21
<b>8. MAINTENANCE AND REPAIR WORK.....</b>	<b>23</b>
8.1 MAINTENANCE .....	23
8.2 REPLACING THE NOZZLE .....	23
8.3 REMOVING THE VALVE INSERT.....	25
8.4 FITTING THE VALVE INSERT .....	26
8.5 CLEANING THE PISTON DRIVE AND PISTON DRIVE CHAMBER.....	26
8.6 REMOVAL / INSTALLATION OF THE CONTROL UNIT .....	26
<b>9. TROUBLESHOOTING.....</b>	<b>28</b>
9.1 SPRINKLER MALFUNCTIONS .....	28

## 1. General

We presume that you are experienced in the field of irrigation. We have therefore kept these instructions brief and included only the information that it is imperative for you to have to use this product.

Any warranty claims can be accepted only if the sprinkler is used in accordance with these operating instructions and if any defect emerges within the warranty period.

We reserve the right to make changes in line with technological advances, including without prior notice.

## 2. Safety

These operating instructions contain some fundamental instructions that must be followed when installing, operating, servicing and maintaining the sprinkler. It is therefore imperative that these instructions are read by the fitter and the relevant specialised staff / operators prior to installation and commissioning.

Attention must be paid not just to the general safety information set out in this 'Safety' section, but also to the special safety instructions included in the other sections.

### 2.1. Use of symbols in these operating instructions

Where failure to follow safety information can place individuals at risk, such information is specifically marked in these operating

instructions with the general danger symbol



Warning of potential hand injuries



Warning of potential automatic start-up

In the case of safety information, where failure to follow it can damage the sprinkler and/or impair its function, you will see the word:

**WARNING**

## 2.2 Proper use

The sprinkler is used for the even distribution of water onto lawns, green spaces and sports fields laid with natural or artificial grass. The water should be pre-cleaned and free of any coarse or fibrous contamination. The water and ambient temperatures must be below the limits specified in the technical data.

## 2.3 Clearly improper use

- ☆ Operation of the pop-up sprinkler by unauthorised personnel (if the control unit is freely accessible).
- ☆ Operation of the sprinkler with the sector to be watered wrongly set, e.g. as the result of vandalism. This can result in the jet of water being directed to the side away from the grassed area.

## 2.4 Safety information



Read the operating instructions, especially the safety information, before starting any work on or with the sprinkler.

The specific safety instructions appear at the start of each section.

## 2.5 Dangers of failing to observe safety instructions

Failure to observe safety instructions can result both in people being placed at risk and in damage to the environment and machine. Failure to observe safety instructions can lead to the loss of any rights to claim compensation.

### 3. Description



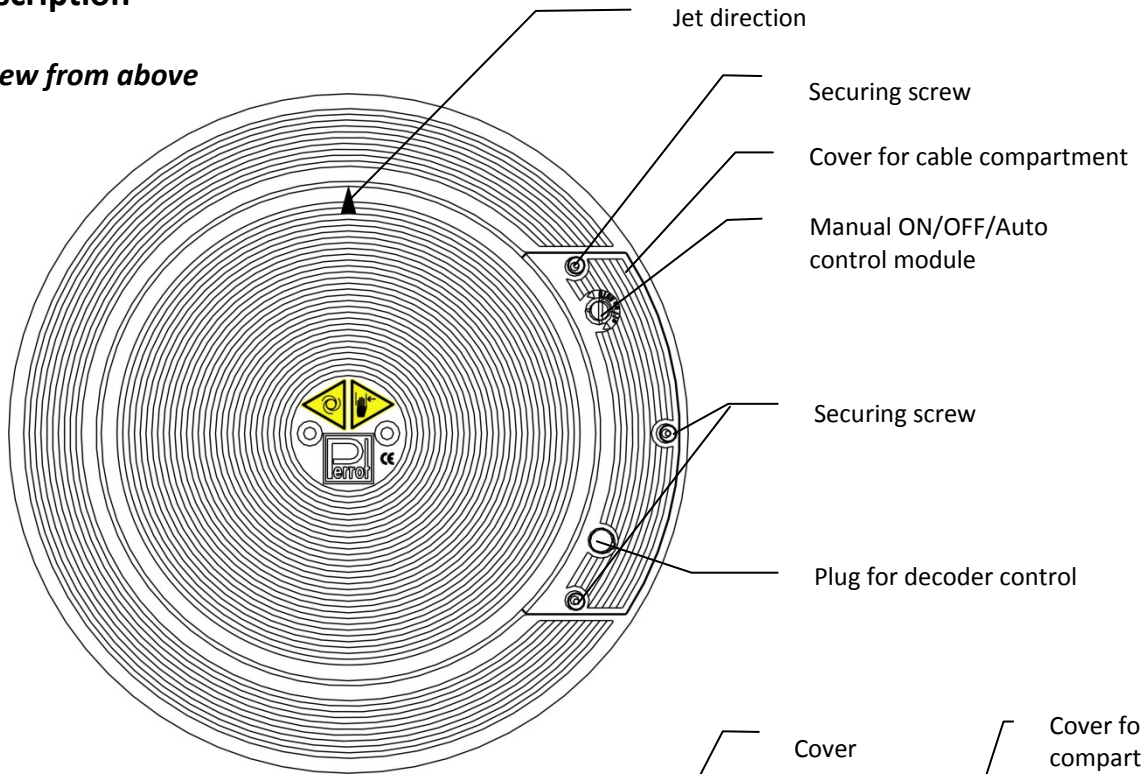

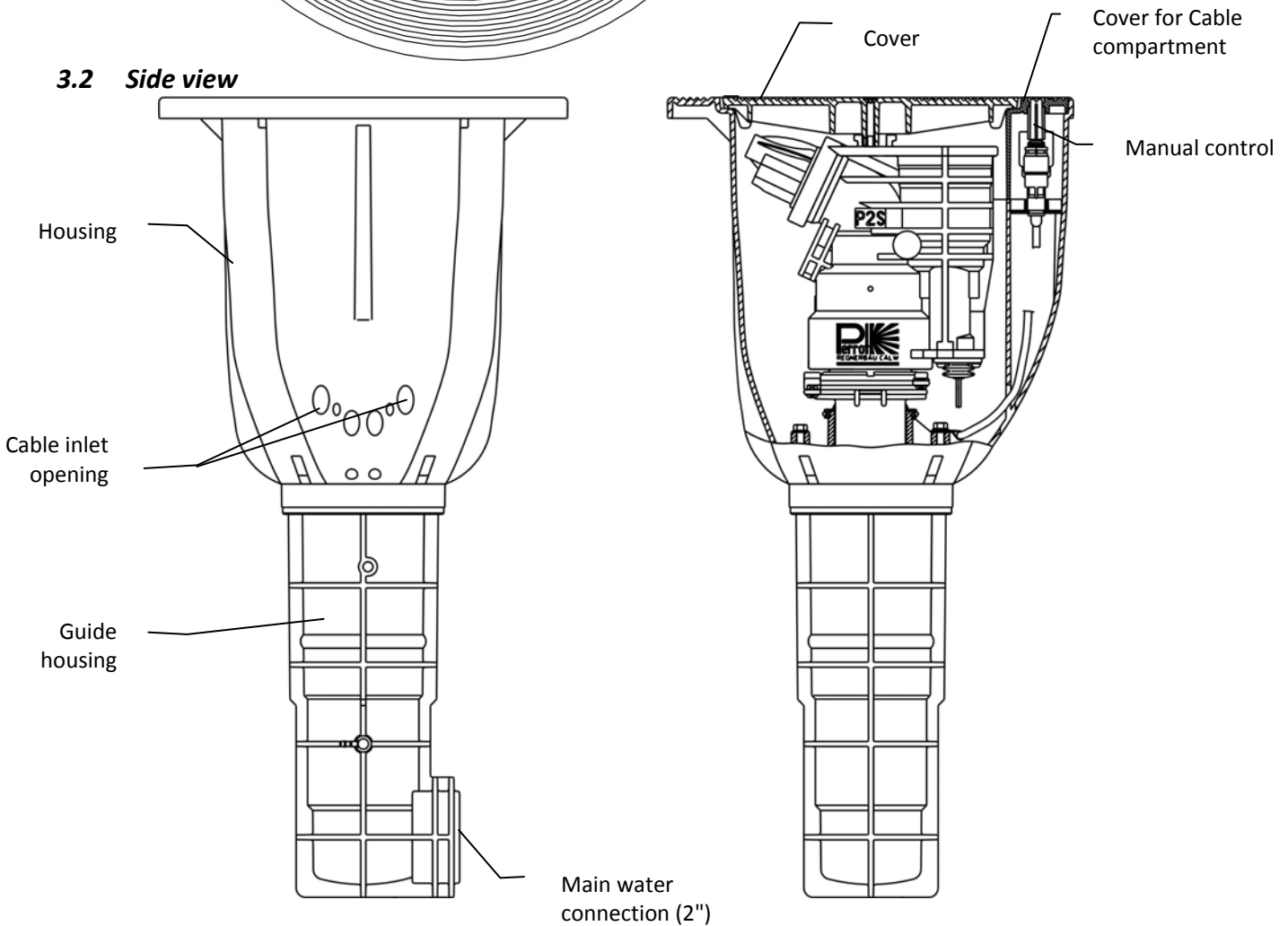

#### 3.1 View from above



#### 3.2 Side view



### 3.3 Special tools

VP3 retaining ring removal hook	Remove retaining ring		RT17839
VP3 retaining ring pliers	Fit and replace retaining ring		RT17844
VP3 valve lifter	Remove valve		RT25359
Face hole key	Piston motor cover		ZB98236
VP3 flush insert	Flush main line		RB25380
VP3 assembly key for nozzle	Changing nozzle		RB25189
TORX-key	for screws at the lid		ZB98289

## 4. Technical data

Recommended operating pressure 4 to 8 bar

Permitted operating pressure 4 to 10 bar

**WARNING**

The pressure at the sprinkler may not exceed 10 bar

Connection thread: G2" FT

Liquids: Water

Liquid temperature: 40°C max.

Ambient temperature: 60°C max.

For further data see separate data sheet.

## 5. Assembly, set-up and installation

### 5.1 Hazard warnings



If any impurities get into the sprinkler, it is possible that the sprinkler could be destroyed and that fitters could be injured. Therefore flush out the line thoroughly before connecting the water supply.



Any unexpected emergence of a jet of water can lead to serious injury. Therefore make sure that the installation has been fully completed before turning on the water supply.

### 5.2 Installation instructions

- ☆ The thread connection on the pop-up sprinkler is 2" FT.
- ☆ For the thread seal use hemp and sealing compound, e.g. Fermit Spezial or teflon tape.
- ☆ The pop-up sprinkler should be fitted in accordance with the 'Perrot VP3 pop-up sprinkler installation diagram' (see next page). In order to avoid any load pressure on the main line, you should definitely use a flexible connection.
- ☆ Providing a drainage pit directly connected to the drainage, as shown in the installation diagram, is very much recommended.
- ☆ For screwing in the connection joint the housing or housing edge of the pop-up sprinkler can be firmly held or clamped.

### 5.3 VP3 pop-up sprinkler installation diagram

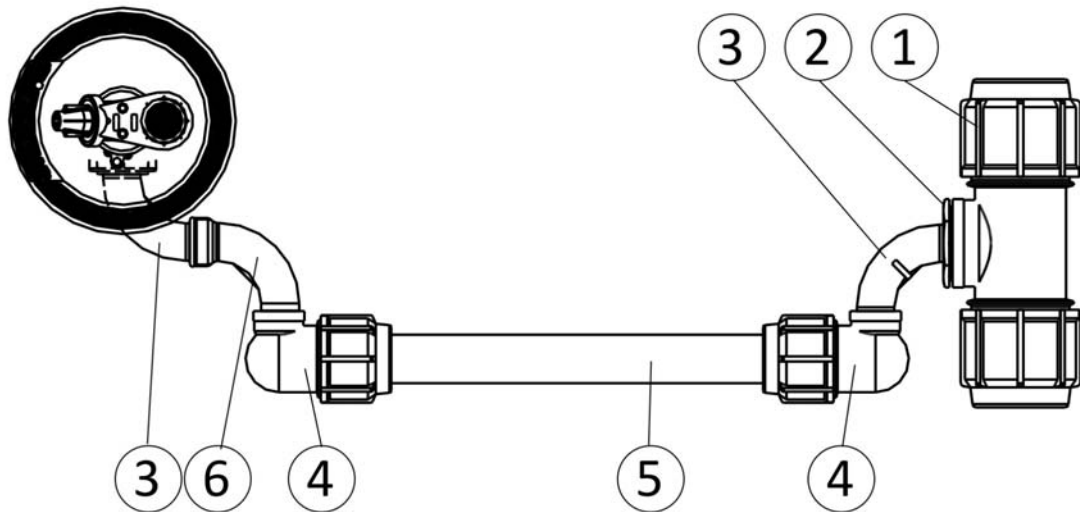
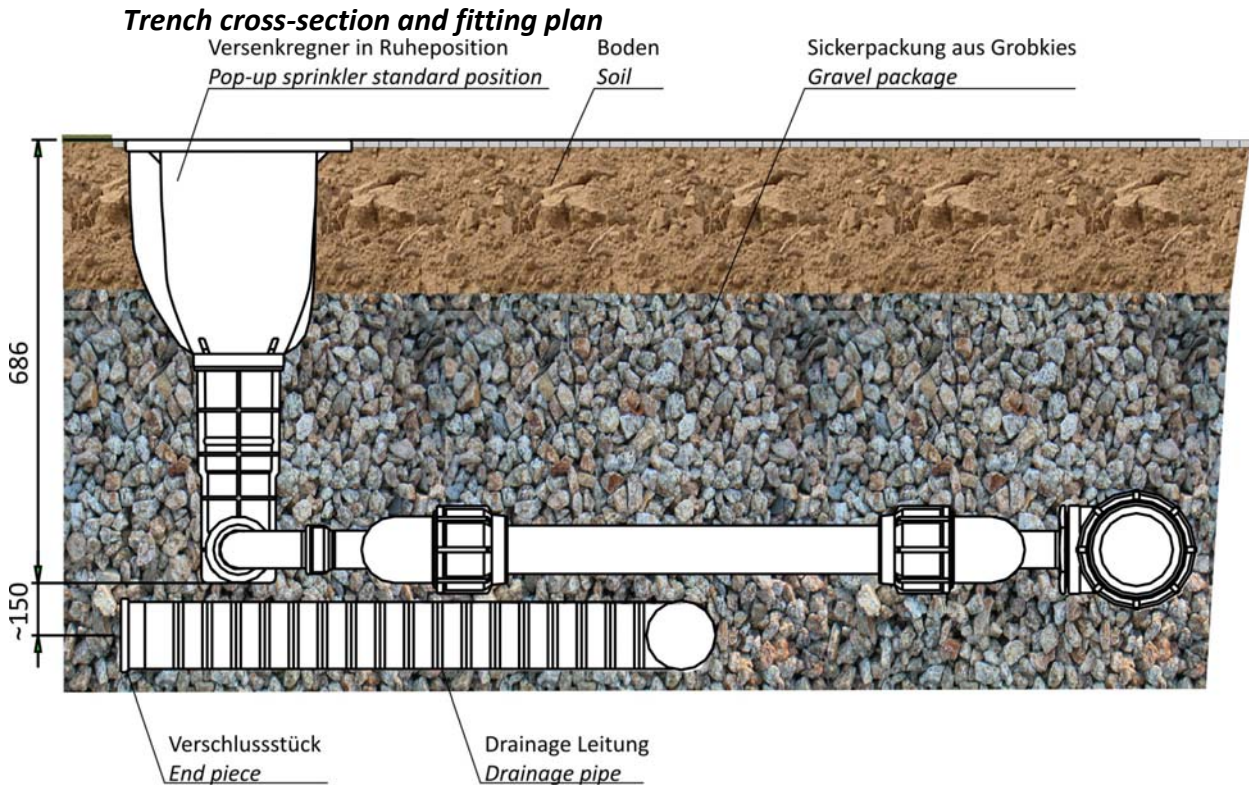

Item	Description	Description	Parts no. Article no.	Ø PE-Hauptleitung / dia PE Main Pipe		
				Ø110	Ø90	Ø75
1	T-Stück 90° 110 x 4" IG	T-piece 90° 110 x 4" FT	ZH90159	1		
	T-Stück 90° 90 x 3" IG	T-piece 90° 90 x 3" FT	ZH90158		1	
	T-Stück 90° 75 x 2½" IG	T-piece 90° 75 x 2½" FT	ZH90157			1
2	Reduziernippel Nr.241 3"x2"	Red. nipple no. 241 3"x2"			1	
	Reduziernippel Nr.241 4"x2"	Red. nipple no. 241 4"x2"		1		
3	Bogen lang 90° Nr.3 2" AGxAG	Elbow 90° no. 3 2" MTxMT		2	2	2
4	Winkel Anschlussverschraubung 75x2" IG	Elbow clamp connection 75x2" FT		2	2	2
5	Rohrstück PE-HD 12,5 Ø75	Pipe PE-HD 12.5 Ø75		1	1	1
6	Bogen lang 90° Nr.1 2" IGxAG	Elbow 90° no. 1 2" FTxMT		1	1	1



**Sprinkler arrangement (schematic only)**

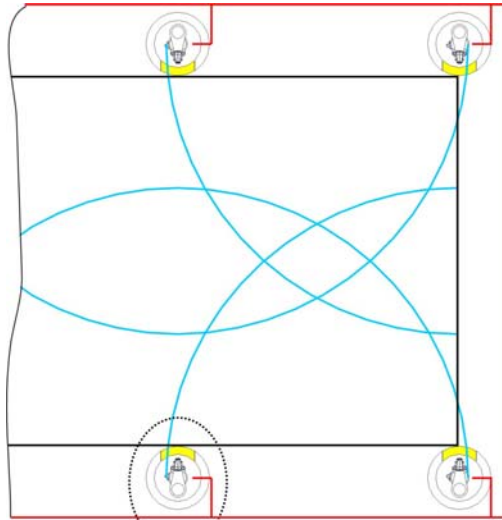

**X**



**Detail X: Sprinkler arrangement upon installation**

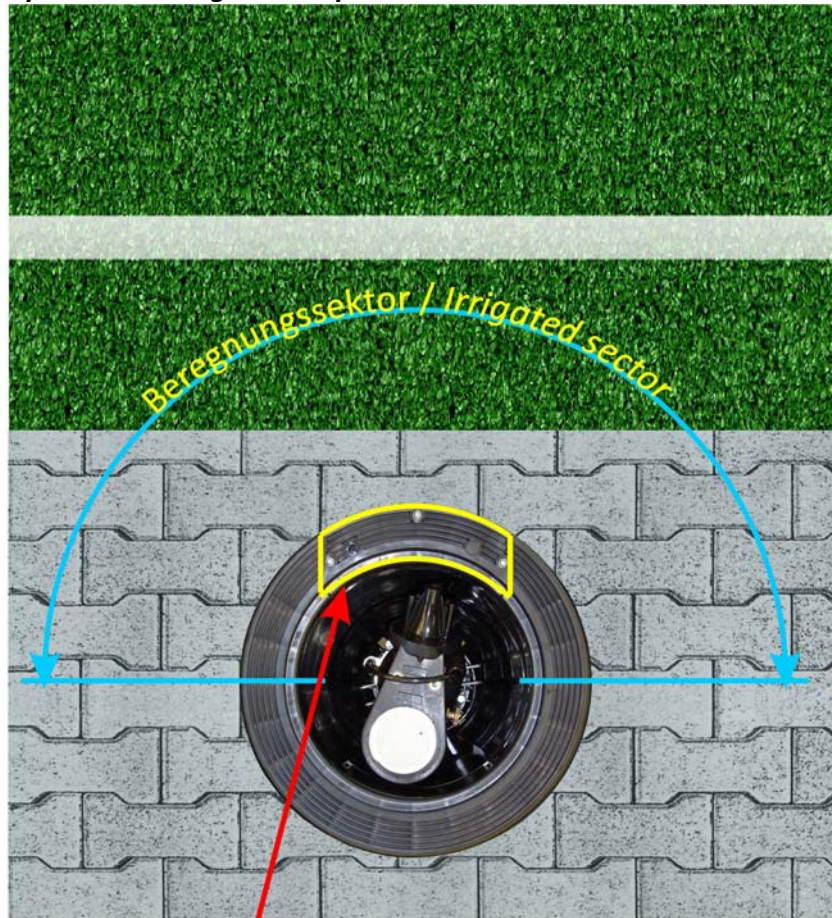

**VP3 sprinkler has to be installed in that way, that the top accessible cable box is on the side of the irrigated area.**

**5.4 Installation scheme for VP3 with rubber infill lawn**

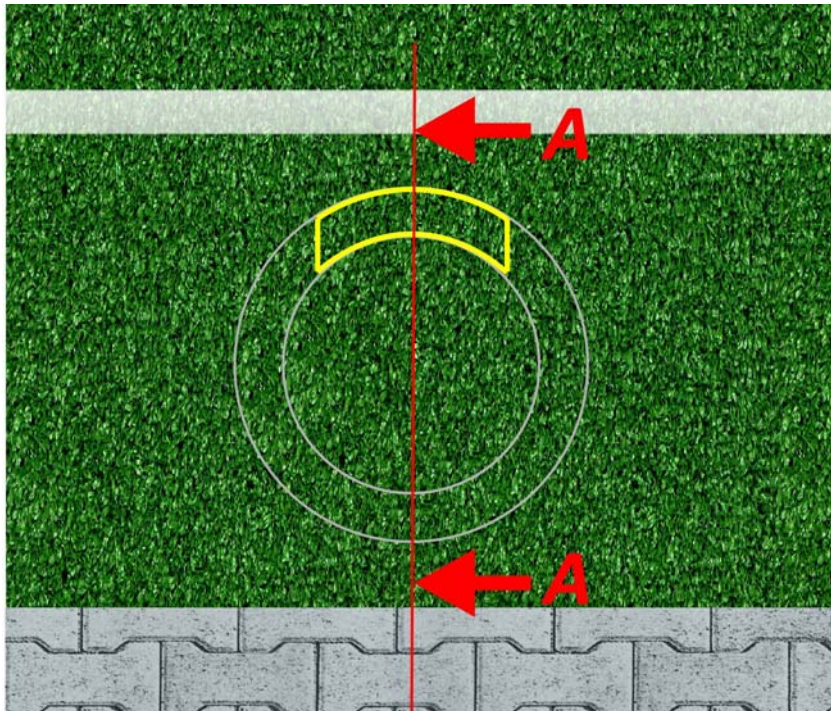

**Schnitt A-A**  
**Section A-A**

Gummigranulat  
(Verfüllhöhe sollte 2-5mm unter Rand  
von Gehäuse sein)  
*Rubber infill*  
(Height of infill material should be  
2-5mm less than height of sprinkler frame)

Verklebe-Hinweis für Kunstrasen siehe TDP075  
*Please see TDP075 for adhesive bonding hints  
of the synthetic turf*

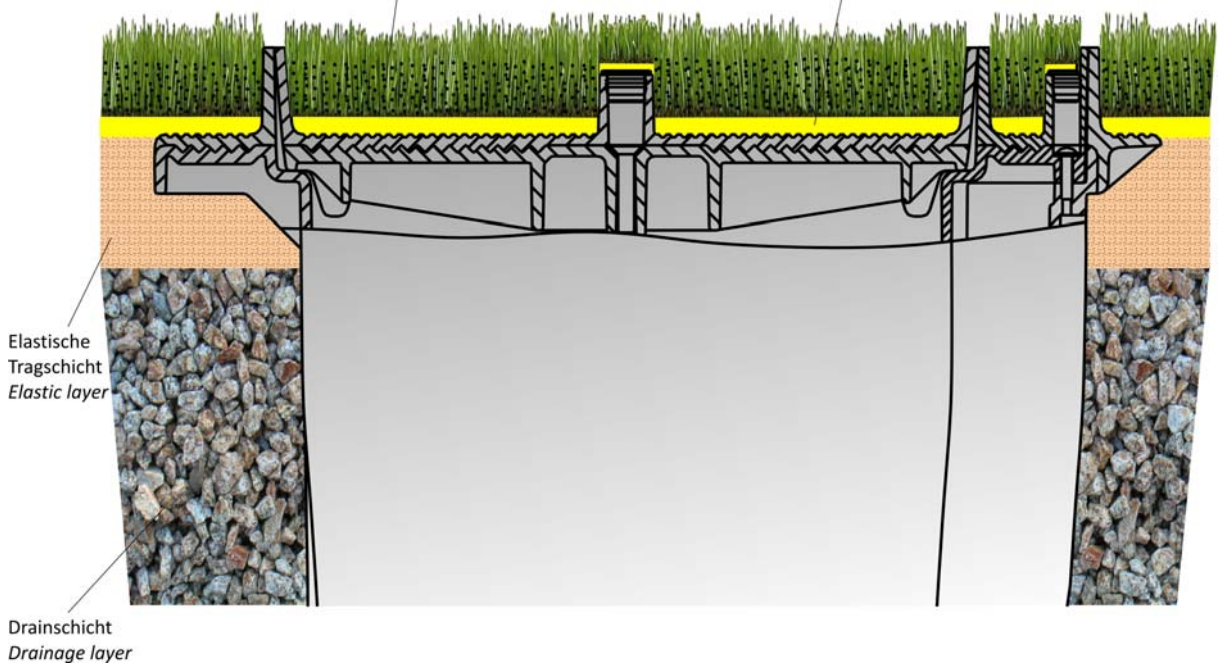

#### 5.4.1 Handling the VP3 pop-up sprinkler with filled synthetic turf

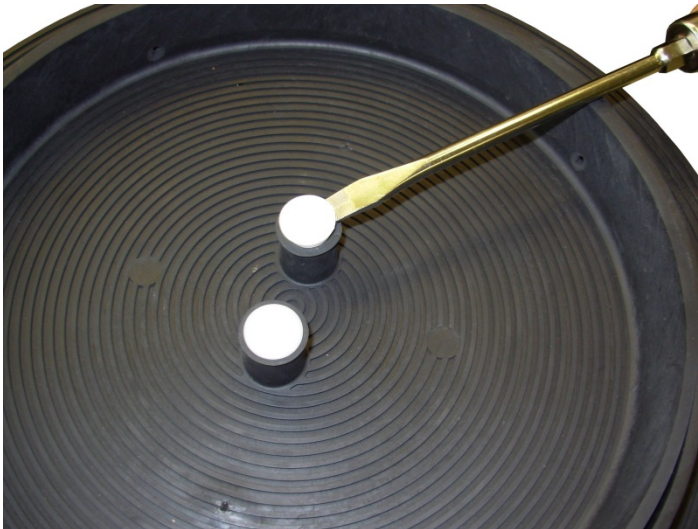

Remove plug so that the lid and the cable shaft cover can be disassembled / assembled see 8.6.

**WARNING**

*Do not plug the drainage holes during adhesive bonding of the synthetic turf.*

#### 5.4.2 Operating instructions for VP3 pop-up sprinkler with filled synthetic turf



Operation of the manual control using an engineered flat-blade screwdriver (1,1 mm x 9,0mm).

Manual control can be opened by turning the engineered flat-blade screwdriver through the cross shaped rubber protection see 6.2. Commissioning

Turn to the left – AUTO position

Turn to the right – OFF

Approx. 1-2 full rotation to the left – ON



### **5.5 External start using key switch**

There is a safety circuit with key-operated switch for checking whether any unauthorized people are in the danger zone / area to be watered.

The key-operated switch gets fitted in a position from which the whole danger zone can be clearly seen. Watering begins only when the operator gives the all-clear by turning the key.

For details of how the controller works please refer to the separate TDP072 operating instruction.

### **5.6 Cabeling**

3-core cable laid during installation to the VP3 pop-up sprinkler's electrical connection. The cable is pulled through the right or left opening on the bottom of the housing into the cable compartment.

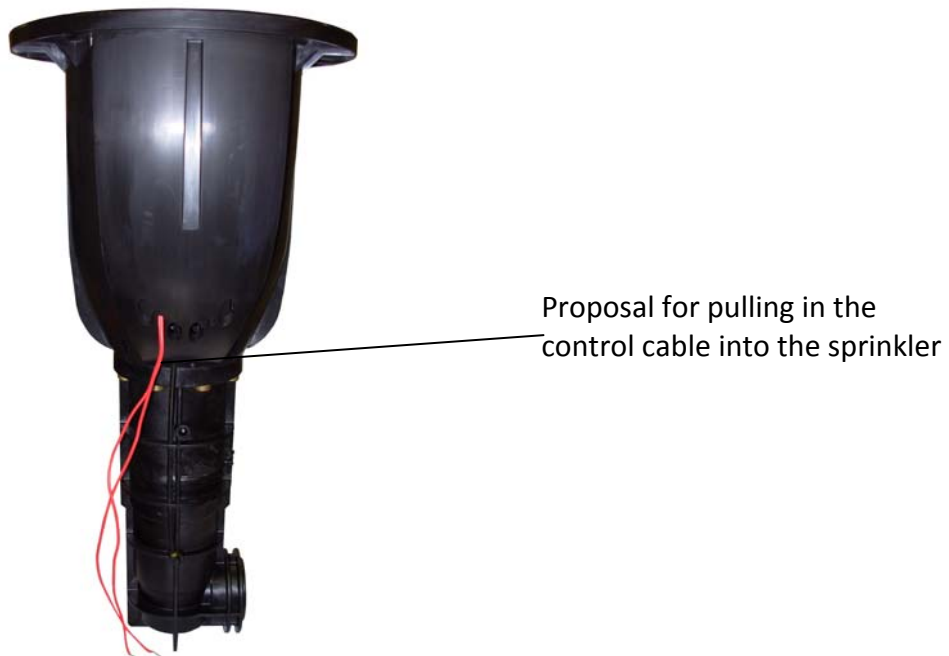

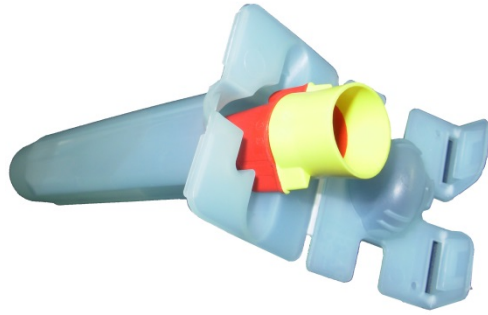

The DBR/Y-6 cable connector kit (article no.: ZH90032) for connecting the control cable to the coil fitted inside the sprinkler.

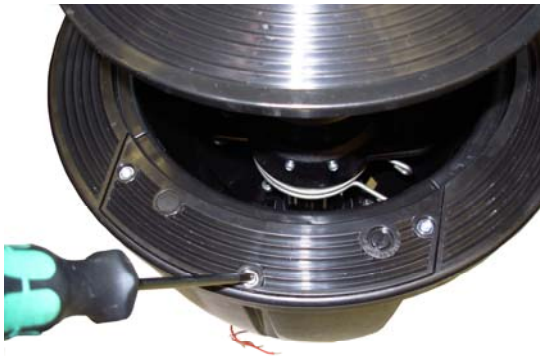

Open the cover of the cable compartment and attach cable connector.



Put back the cables into the cable compartment and close the cover.

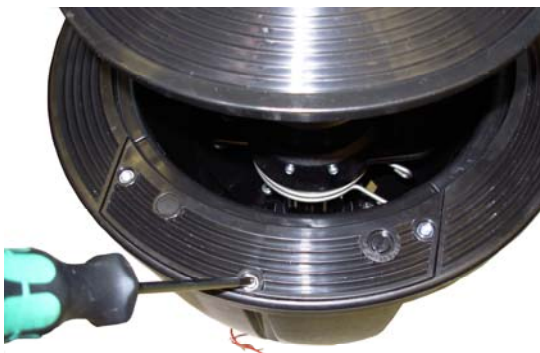

The electrical connection is thus not exposed to the soil, but is instead protectively integrated inside the sprinkler and accessible again at any time. This simplifies any search for faults and any maintenance work can be carried out at any time without any earthwork.

**Cable plan (schematic only)**

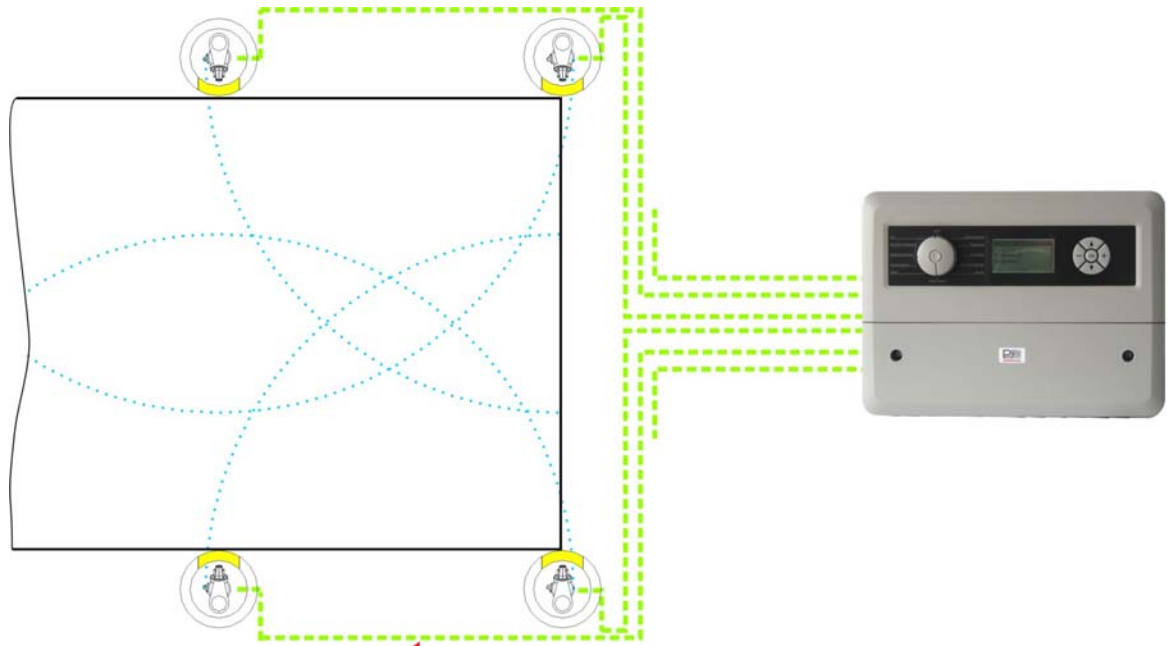

**Control cable specification: Suitable for underground installation  
PVC insulated and EPDM sheathed cable, NYY  
For VP3: NYY 2x2.5mm<sup>2</sup> RE**

For further details please see separate operating instructions for Water Control (TDP072).

## 6. Commissioning and operation

### 6.1 Potential danger



When it starts up, the pop-up sprinkler rises up out of the housing and builds up full pressure within about 5 seconds. The **jet of water emitted** can cause injury. For this reason the following guidance must be followed when commissioning and operating the sprinkler:



- When **the sprinkler is being operated in automatic mode, there must be nobody present in the area.**
- Operating personnel **must not stand in the direction of the sprinkler's jet.** The jet's direction is marked on the cover by an arrow.

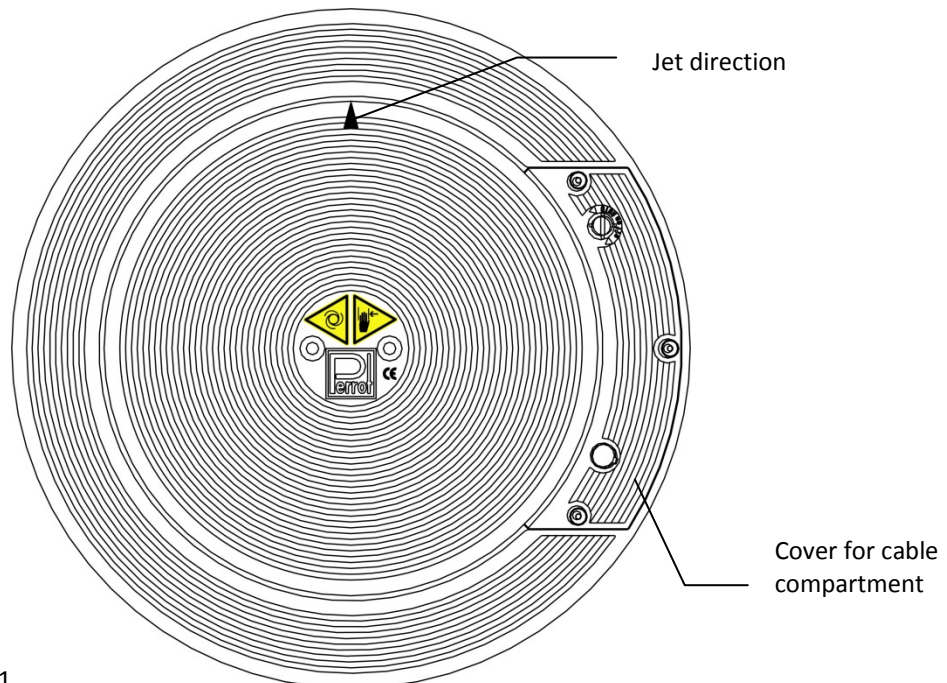

Figure 1



If the sprinkler is not installed flush with the ground, people may be injured by a fall as a result of stumbling or tripping. Therefore check prior to commissioning and regularly during ongoing use whether the sprinkler cover shuts flush with the surrounding ground.



The sprinkler must not be operated without a closed cover for the cable compartment. During operation the sprinkler head props itself against the edge of the cover and cannot rotate freely without the cover.

## 6.2 Commissioning

- a) Check electrical function:  
Before any water supply to the sprinkler is opened, activate the coil by means of the controller. If you hear a 'clicking' sound from the coil, the electrics are working properly. (The click is produced by the movement of the armature.)
- b) Ensure that <Manual opening> is set to AUTO (**turn screw for <Manual opening> as far as it will go to the left**). This setting ensures that after water is supplied the sprinkler closes if it has no power.
- c) Slowly open supply of water to the sprinkler until operating pressure is built up. It is possible that the sprinkler will briefly open, but should then automatically close after at most 30 seconds.
- d) Once the water supply has been opened and max. operating pressure has been reached, check sprinkler and connection for leaks.
- e) Check that sprinkler is working properly: Open sprinkler using <Manual opening> by moving the screw for <Manual opening> into the position between AUTO and OFF (approx. 1 rotation). Sprinkler head rises and starts to rotate.



**Do not stand in front of the nozzle opening!**

- f) Close <Manual opening> and put into AUTO position (see point 6.2b). Sprinkler must stop water flow within 30 seconds.
- g) Keep repeating steps 'e' and 'g' until the sprinkler is working faultlessly.
- h) Check once again that it works correctly when activated electrically from the controller.





The following points 6.3, 6.4 and 6.5 should ideally be carried out with the sprinkler running.

First fold out the safety catch to the side of the sprinkler head (see illustration 2) so that no limbs (e.g. fingers) can get jammed if the sprinkler should unexpectedly close.

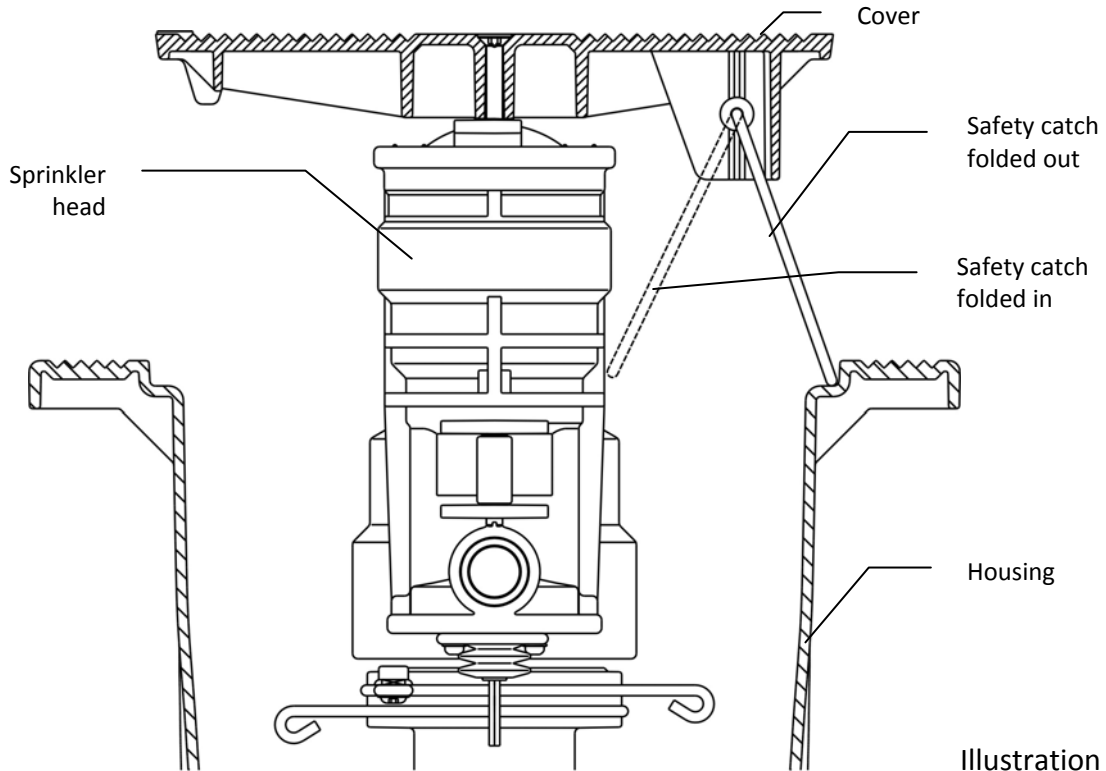

Illustration 2

No special procedures are needed to set the sprinkler. All you need to set are the sprinkler's rotational speed and, when using it in back-and-forth mode, the sector to be watered.

### 6.3 Setting the sector

With this pop-up sprinkler the sector setting is infinitely variable. You can adjust the area to be watered by pulling on the relevant end of the top or bottom spring stop.

#### Setting the sector angle

**WARNING** Infinitely variable setting is possible by pulling (not pressing) on the relevant end of the top or bottom spring stop.

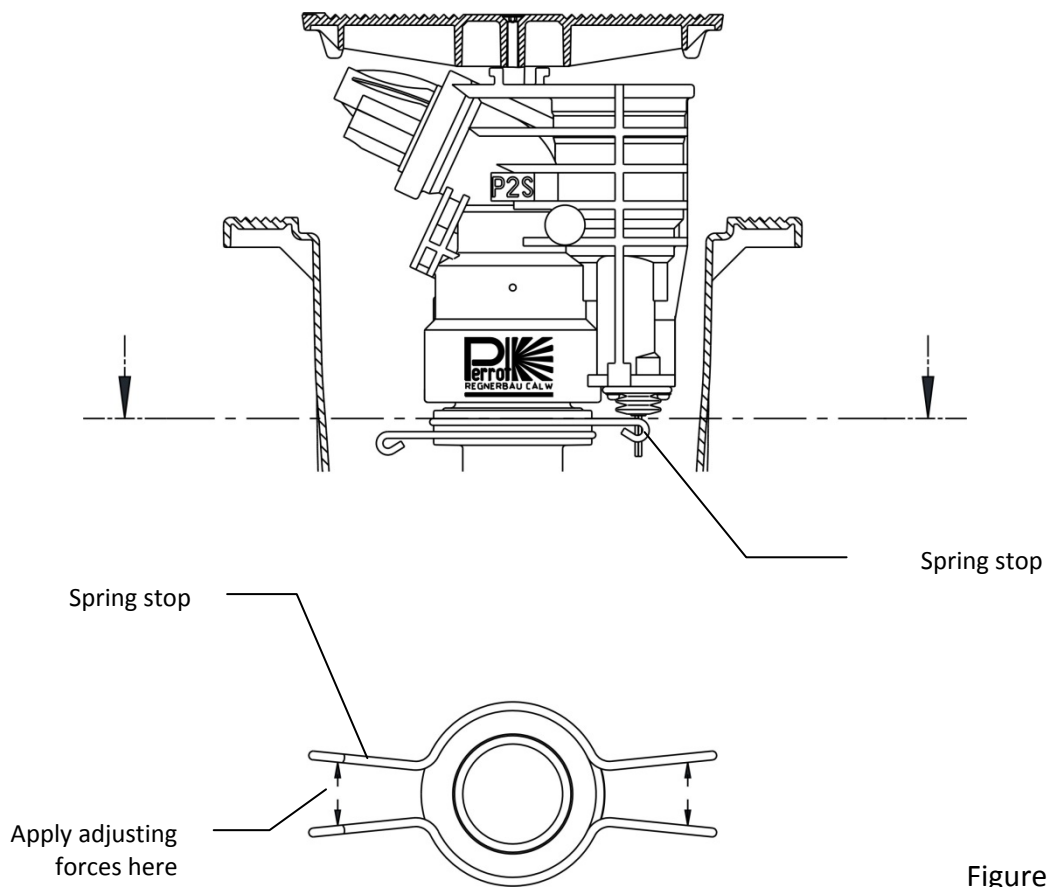

Figure 3

#### 6.4 Full-circle irrigation

For full-circle irrigation the spring stops need to be removed.  
First, the sprinkler module needs to be removed from the housing.  
(See point 8.3).

#### WARNING

***Pull spring stop apart at both ends only to such extent that they can just be slid off.***

***If the spring stops get overextended, it will not be possible to use them any more for back-and-forth operation.***



Gently pull both spring stops apart and remove downwards.



Now splay the spring stops over the sliding pipe and pull off.  
New spring stops are fitted in reverse order.

Any overextension of the spring stops must be avoided, as otherwise it can no longer be certain that they will fit tightly and it will no longer be possible to set the irrigation sector's switch-over point when reverting to sector operation.

## 6.5 Regulating the speed

Turning the regulating screw to the right reduces the rotational speed.



**Option:**

It is possible for the sprinkler to be **completely stopped** when the speed-regulating screw is turned to the right.

If you turn it to the left, the rotational speed gets increased again.

**WARNING**

***Irrigate at reduced speed only if the water is clear.***

***If the water is dirty, the regulating screw must remain fully opened. Otherwise there is a risk of the sprinkler stopping.***

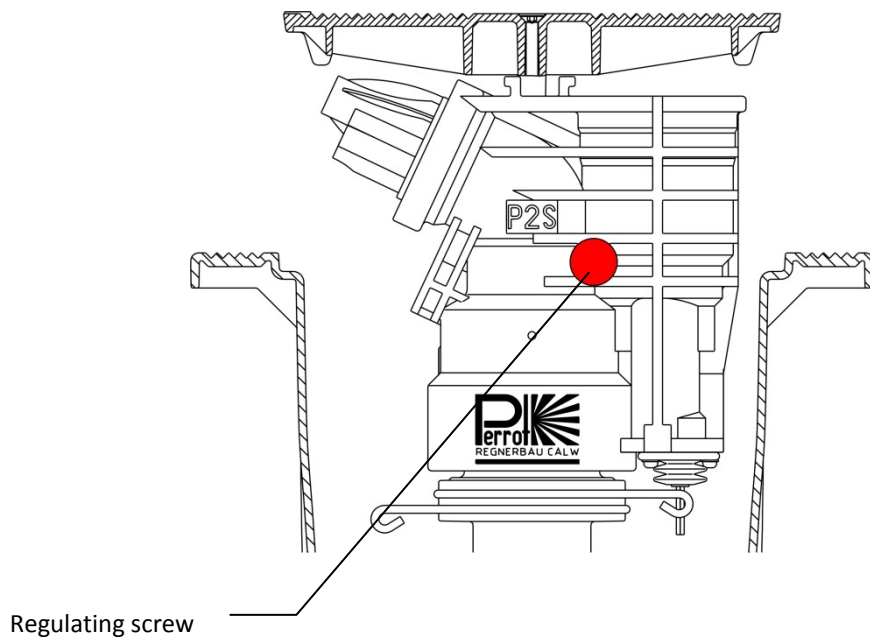

Figure 4

## 7. Decommissioning and preparing for winter

For decommissioning please turn off the water supply and electricity supply of the pump.

### 7.1 *Preparing for winter*

During times of possible frost please ensure that there is no standing water in the sprinkler.

The VP3 sprinkler has an automatic emptying system.

The sprinkler has a discharge valve and can thus be emptied by gravity. To do this, the water is let out at the deepest point of the main pipe, as a result of which the sprinkler empties itself. (Deep point emptying)

The remaining water in the piston drive causes no damage in the event of freezing. If the sprinkler is taken back into use despite there still being ice in the piston chamber, then, at an ice temperature of approx.  $-20^{\circ}\text{C}$ , it will take around 15 minutes until the drive is thawed out.

#### **WARNING**

Electrically activate the solenoid several times so that any residual water is pushed out of the coil cavity.

During the winter we recommend activating the coil for approx. 1 minute twice a week.

### 7.2 *Springtime commissioning*

As a result of the change of load and diverse installation conditions (damp/dry), the head of the piston sprinkler is subjected to extreme tensions. These circumstances can lead to the piston acquiring some axial play. In order to avoid any operating problems, the piston drive cover should be tightened as described below during spring commissioning in the first and second year of operation.



Before the grey cover can be tightened, the lock screw needs to be removed.

After firmly tightening the grey cover, twist in the lock screw again.



The lock screw prevents the grey cover from working itself loose.



Tighten cover using face spanner ZB98236 and approx. 10Nm of torque. That means, with a lever length of 10cm you need to apply a force of 100N to the spanner.



**Note:**

After the third or fourth winter there should be no further expansion.

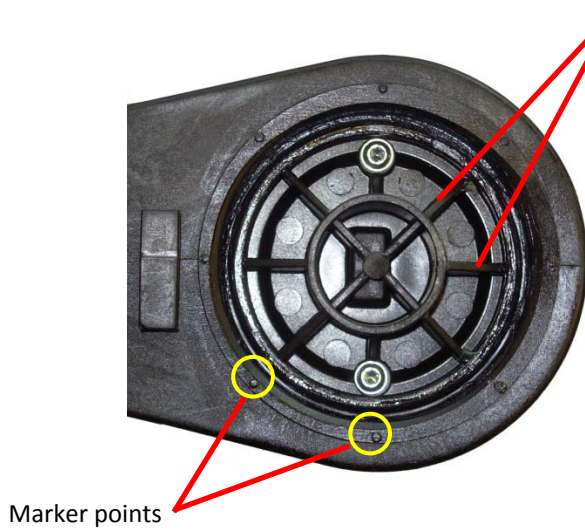

Bracing ribs



**Caution:**

If the lock screw cannot be screwed in, it will hit a piston drive bracing rib! In this case, the grey cover must be tightened a bit more so that the lock screw misses the bracing rib. The orientation of the bracing ribs is indicated by marker points.

## 8. Maintenance and repair work



An unexpected jet of water can cause serious injury. Prior to any maintenance or repair work therefore ensure that the water supply is securely turned off.

### 8.1 Maintenance

- ☆ After one year of use, tighten the M6 flange screws (8 of them) using a 10mm box spanner to ensure that the sprinkler module is fixed firmly in place. Tightening torque  $9^{+1}$ Nm.
- ☆ Clean out the inside of the sprinkler housing using an industrial vacuum cleaner or similar (as necessary).
- ☆ Cut sprinkler housing free of any overgrowing grass. It makes sense to carry out these jobs prior to spring commissioning.
- ☆ Regularly check that the sprinkler is flush with the surface, especially in the case of natural grass.

### 8.2 Replacing the nozzle

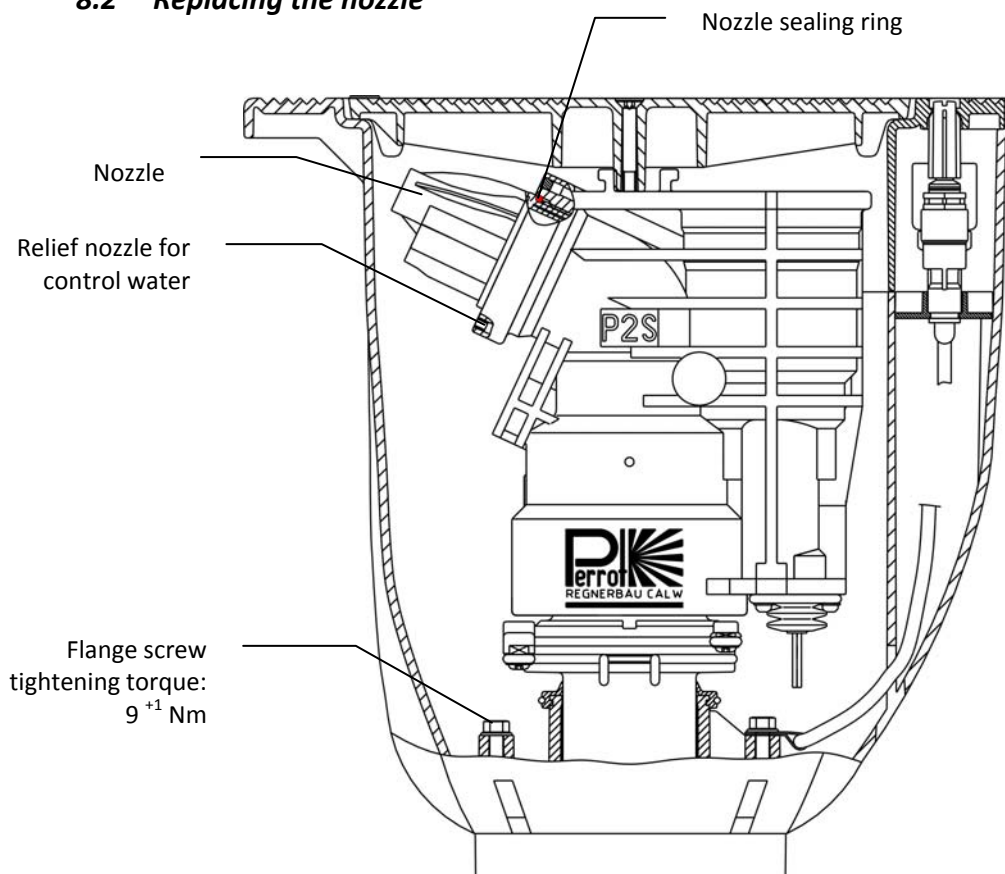

Figure 5

When changing the main nozzle the nozzle's thread should be cleaned and greased. This enables the nozzle to be easily loosened by hand (using the assembly key RB25189) and just as easily tightened again.



Wrong position



Right position

When fitting the nozzle make sure that the funnel gets pushed on in the right position. (See picture.)



If the funnel is not properly fitted first, the nozzle cannot be screwed into the manifold head.

**WARNING**



***When fitting the new nozzle, make sure that the nozzle gets fully screwed in, that the main secondary nozzle points downwards (6 o'clock position) and that the sealing ring is correctly fitted (figure 5).***



### 8.3 Removing the valve insert

The sprinkler module needs to be taken out of the housing in order to carry out the repairs described below.

- ☆ Unscrew cover using 5mm Allen key.
- ☆ Remove the 8 flange screws using a 10mm box spanner.

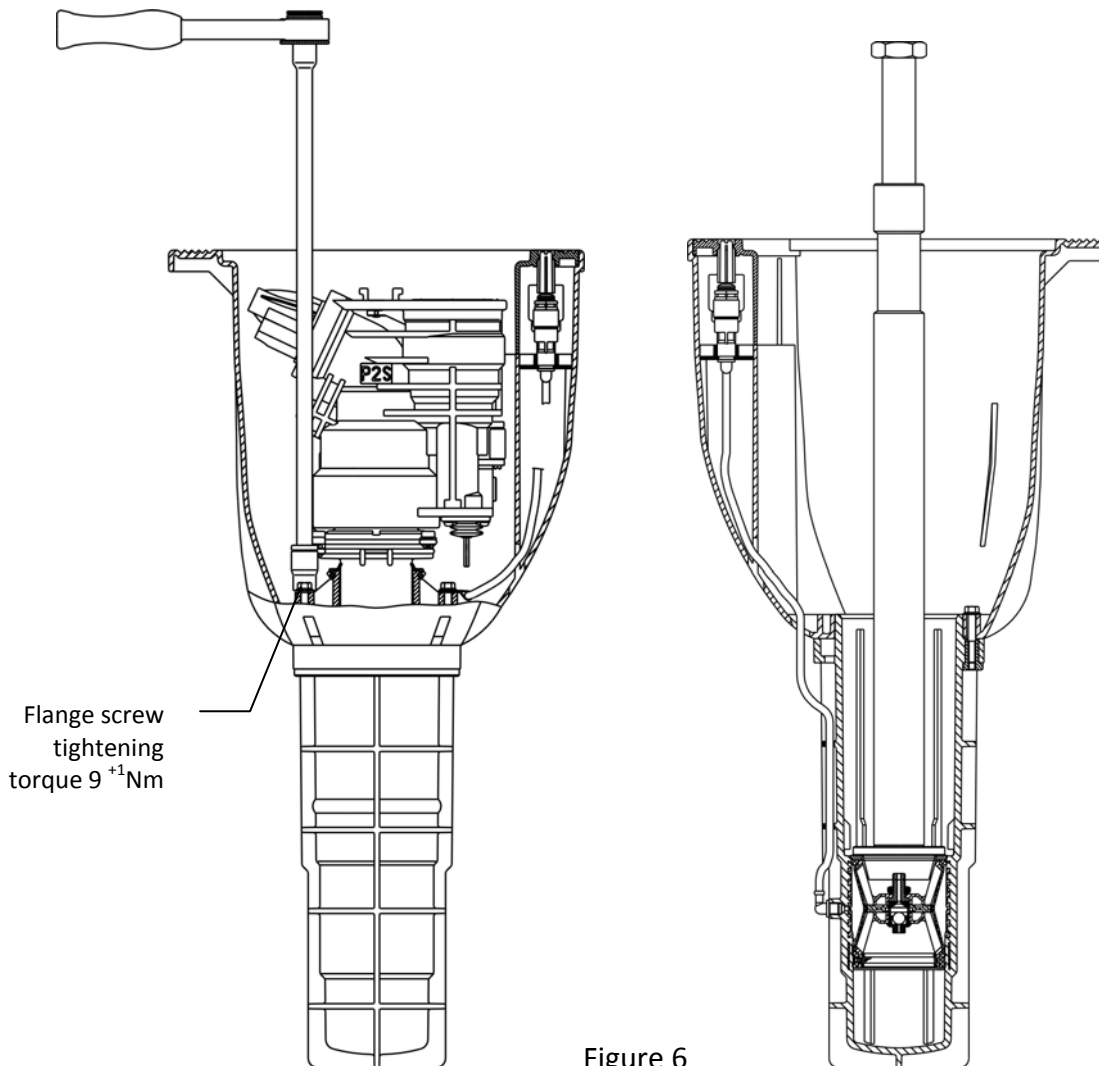

Figure 6

- ☆ Pull sprinkler module out of the housing.
- ☆ Remove retaining ring in the housing bottom using removal hook RT17839.
- ☆ Screw valve lifter RT25359 in the housing base onto the valve and pull upwards. It is possible that for this a few gentle hits may be necessary in order to take off the valve.

#### 8.4 Fitting the valve insert

- ☆ Fitting the valve using valve lifter RT25359.
- ☆ Prior to fitting, check valve for any damage to the membrane.
- ☆ Check for any dirt and clear away.
- ☆ Screw the valve insert with the stainless steel disc onto the valve lifter. The chambered surface of the stainless steel disc must point to the valve insert.
- ☆ In order to make fitting easier, the valve insert can be slightly lubricated with oil or grease.
- ☆ Insert the valve down into the guide housing by applying some gentle taps.
- ☆ Using pliers RT17844, now fit the retaining ring into the groove provided for it above the thrust washer.

**WARNING** *The sprinkler insert is fitted in reverse order.*

#### 8.5 Cleaning the piston drive and piston drive chamber

If due to becoming very dirty the drive is no longer working, the piston drive should be taken out and cleaned.

Removing the piston drive: See repair guide *TDP055-rep*.

#### 8.6 Removal / installation of the control unit



**Ensure sprinkler is not under pressure.**

##### *Taking out the control unit*

- ☆ Lift cover and fix with safety catch.

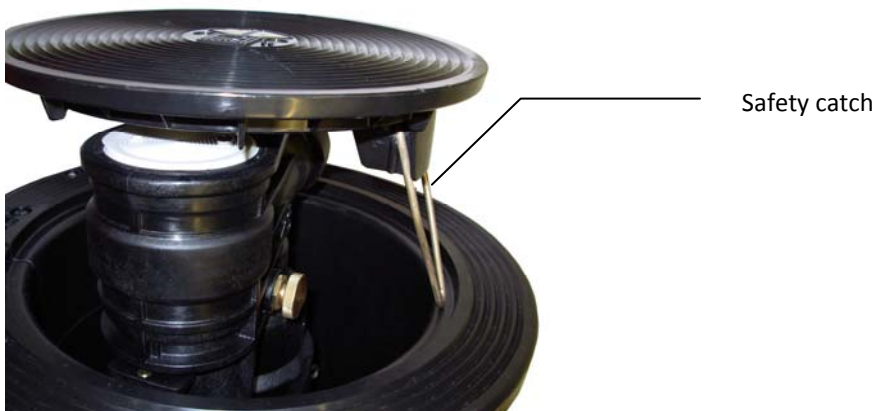

- ☆ Undo all 3 locking screws and take off cable compartment cover.
- ☆ Unclip control unit from protective casing and lift up.

- ☆ Twist out coil.
- ☆ When replacing the control unit, press back the mounting ring at the plug-in connector and pull out the hose.

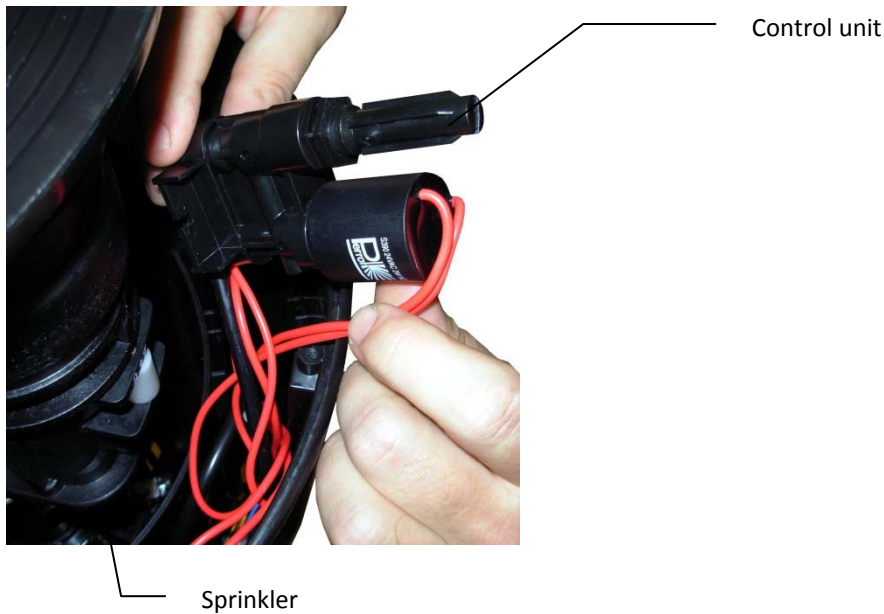

### ***Fitting the control unit***

- ☆ When buying a replacement part, the control unit is supplied with plug-and-socket connections. Push hoses into plug-in grommets as far as they will go and ensure that the mounting ring springs back.
- ☆ Screw in coil.
- ☆ Clip control unit into protective casing.
- ☆ Secure housing cover using all three screws.
- ☆ Check sprinkler is working properly as per point 6.2.

## 9. Troubleshooting

### 9.1 Sprinkler malfunctions

Malfunction	Cause	Remedy
Sprinkler not rotating or only very slowly. Sprinkler not rotating at all.	Dirty water. Speed regulator set to minimum. Blocked	Fully open regulating screw, dirt gets flushed out Clean filter See points 8.4 and 8.5
	Defective piston drive	Piston drive must be replaced, see repair instructions TDP055e-rep
Sprinkler has poor jet	Nozzle / funnel is blocked	Unscrew nozzle, remove and clean. When fitting nozzle, make sure it is in correct 12 o'clock position; grease nozzle thread.
Sector angle gets bigger during operation.	Spring stop is loose. Spring force has slackened. Spring stop has been overextended.	Fit new spring stop.
Sprinkler's bearing is leaking.	Groove ring is worn out.	Can be repaired only by the manufacturer
Valve opens/closes only with manual opening, but not on any electric signal	Screw for <Manual opening> is set to OFF	Turn screw to the left as far as it will go, to Auto.
	Core is jammed in the coil	Remove coil and clean core
	No / inadequate power supply	Establish 24V AC power supply
	Defective coil	Check coil resistance (should be approx. 35 ohms) and replace if necessary
Valve fails to open even with manual opening	Relief channel for coil blocked	Clean channel
	Control water hole or relief hole blocked	Clean control water / relief hole
Valve fails to close	Supply line under no / insufficient pressure	Establish pressure supply
	Coil seat dirty	Clean coil seat
	Bits of dirt between valve seat and sealing plate	Clean valve seat and sealing plate
	Defective membrane	Remove valve and replace membrane
Output pressure at sprinkler nozzle too low or casting range too short	Control water filter dirty	Clean control water filter
	Stones and bits of dirt are hindering an unimpeded passage of water	Clean valve and flush sprinkler
	Valve insert is blocked	Clean valve insert see point 8.3

We reserve the right to make changes in line with technological advances, including without prior notification.

## CE declaration of conformity

**In compliance with Machinery Directive (98/37/EC), appendix II A**  
**In compliance with EC Low Voltage Directive (73/23/EEC)**  
**In compliance with EC Directive on Electromagnetic Compatibility (89/336/EEC)**

The manufacturer: Regnerbau Calw GmbH  
Industriestrasse 19-29  
75382 Althengstett – Germany  
Tel. +49-(0)7051-162-0

herewith declares that the following product

Product name: VP3 large-area pop-up sprinkler  
Year made: from 2014

conforms with the provisions of the directives indicated above.

The following harmonised standards were applied:

DIN EN 292-1; Safety of Machinery – Basic terms, general  
EN 12100 design principles; part 1: General principles and specifications

DIN EN 1050 Machine safety; guidelines for risk assessment

DIN EN 60204-1 Machine safety; electrical equipment of machines; part 1: General requirements (IEC 204-1:1992, modified)

Original versions of the operating instructions for the machine and of the technical documentation have been provided.

This declaration of conformity loses its validity if any modifications are made to the machine that we have not first agreed and approved in writing.

Althengstett,

20.05.2014

Date

Günther Flik, Director of Engineering

Signatory and signatory's details



Signature