

Operating Manual

Pop-up Sprinkler

Hydra S (W)VAC

PERROT





Contents

1	SAFETY	3
1.1	HOW INSTRUCTIONS ARE MARKED IN THIS MANUAL.....	3
1.2	HAZARDS OF IGNORING SAFETY INSTRUCTIONS	3
2	DESCRIPTION	4
3	INSTALLATION	5
4	SPECIAL TOOLS	5
5	COMMISSIONING / PREPARING FOR WINTER	6
5.1	COMMISSIONING	6
5.2	PREPARING FOR WINTER	7
6	SETTING IRRIGATION SECTOR	7
7	REPLACING THE NOZZLE	10
7.1	ADJUSTING THE INLET NOZZLE	12
7.2	FITTING THE SPRINKLER INSERT	13
8	VALVE INSERT REMOVAL / INSTALLATION	14
8.1	TAKING OUT THE VALVE	14
8.2	TAKING OUT THE COARSE FILTER – ONLY IF SEEN TO BE DIRTY	15
8.3	FITTING COARSE FILTER.....	16
8.4	FITTING THE VALVE	16
8.5	FITTING THE SPRINKLER INSERT	17
9	CONTROL UNIT REMOVAL / INSTALLATION	18
9.1	TAKING OUT THE CONTROL UNIT.....	18
9.2	FITTING THE CONTROL UNIT.....	19
10	REMOVAL / FITTING OF MANUAL OPENING AND PRESSURE REGULATING INSERTS	19
10.1	REMOVAL OF MANUAL OPENING AND PRESSURE REGULATING INSERTS	19
10.2	FITTING MANUAL OPENING AND PRESSURE REGULATING INSERTS	20
11	MAINTENANCE	20
12	TROUBLESHOOTING	21
12.1	MALFUNCTIONS.....	21

1 Safety

This operating & safety manual contains fundamental advice to be heeded during installation and operation. It is therefore imperative that the fitter and relevant engineer / operator read this manual thoroughly prior to commissioning and operation.

Please follow both the general safety instructions specified in this 'safety' section and the specific safety warnings included in other sections.

1.1 How instructions are marked in this manual

Safety instructions that, if ignored, could endanger human life or limb are marked with the general "danger" symbol:



"Warning" is printed next to instructions that, if ignored, could be hazardous to the sprinkler and its operation.

WARNING

1.2 Hazards of ignoring safety instructions

Failing to heed the safety instructions may result in danger to life and limb, harm to the environment and/or damage to the device. Failing to heed the safety instructions may lead to the loss of any right to claim compensation.

2 Description

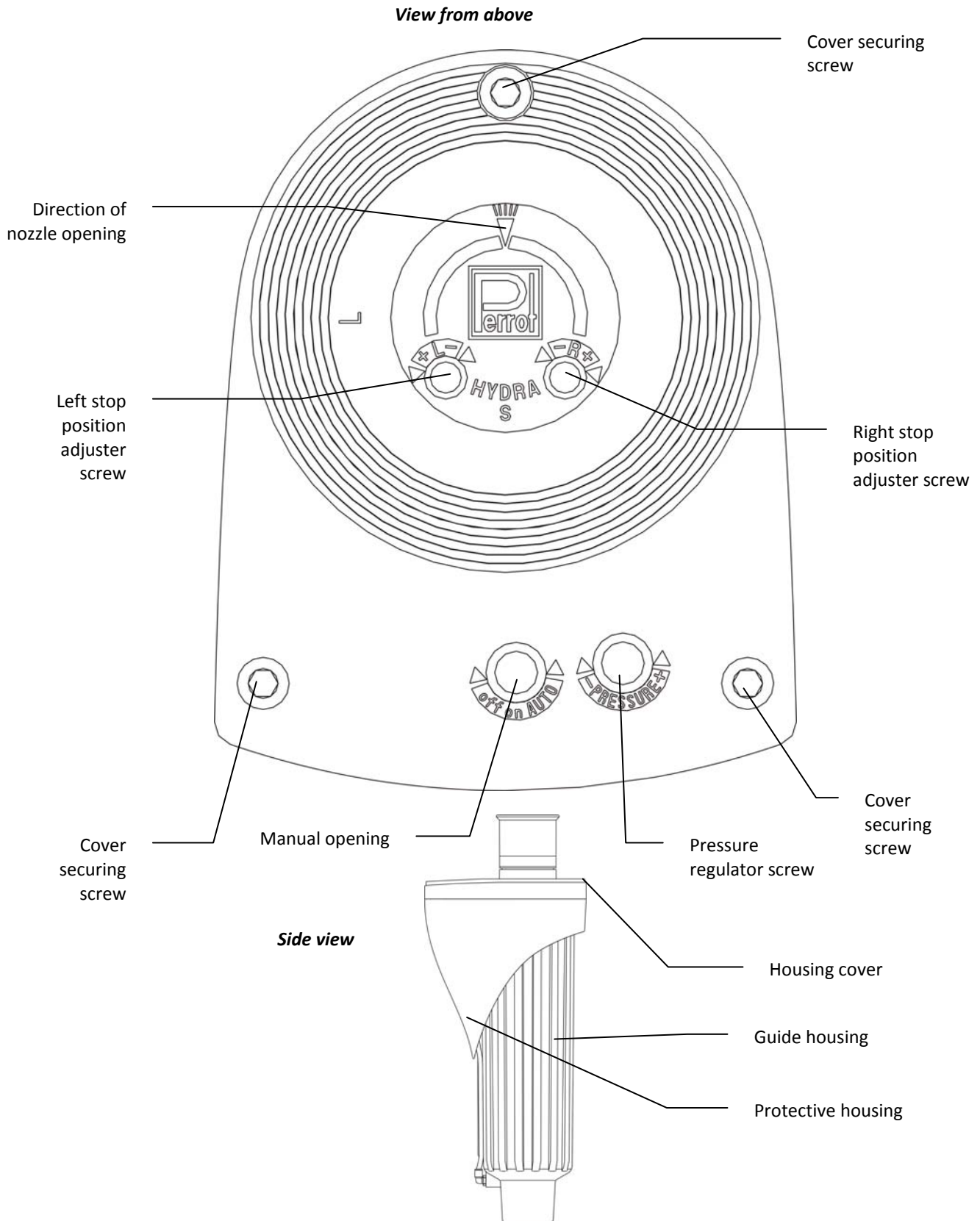





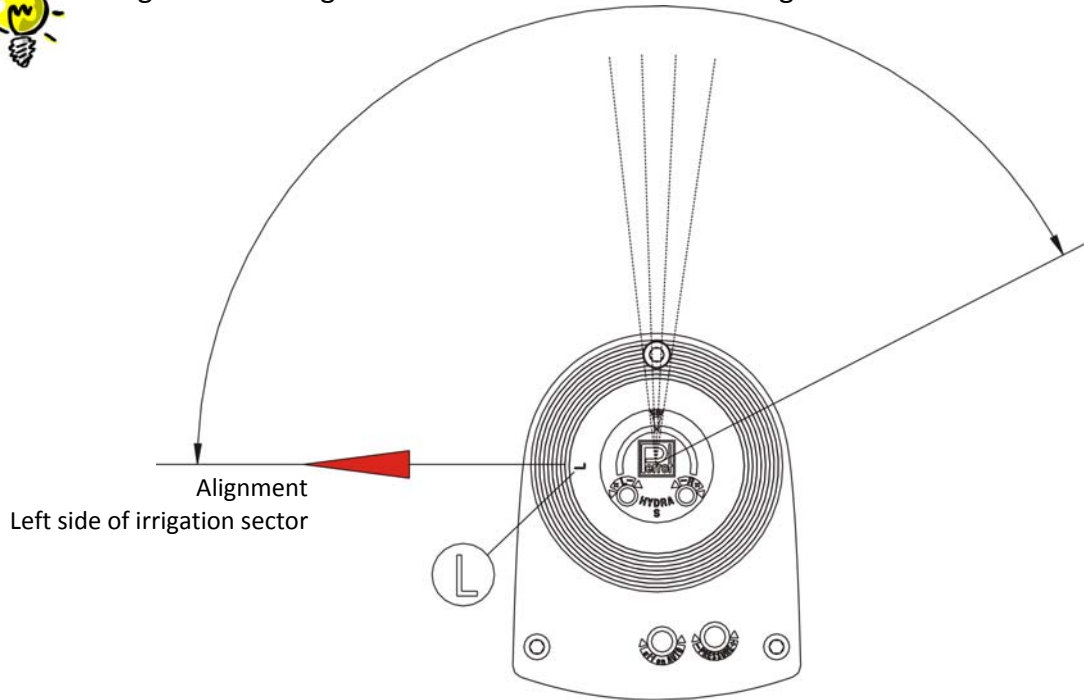



3 Installation

- ☆ Thoroughly flush the pipeline before installing the sprinkler
- ☆ Seal connecting thread with Teflon tape.
- ☆ Note: Part-circle sprinklers must be set up in such a way that the „L“ mark is aligned in a straight line from the left side of the irrigation sector.



4 Special tools

Key for coarse filter Hydra M+S	Disassembly of coarse filter		RT14930
Retainer for sprinkler head Hydra L/M/S	Changing nozzle		RT14031
Flushing equipment Hydra S+M	Flushing pipes		RT14934
Wrench for changing nozzles	Changing nozzles		ZB98276
Retaining ring lifter	Disassembly of valve		RT17839

Retaining ring collet	Assembly of valve		RT17844
Torx-key TX 20	For screws at the lid		ZB98289
Cut off tool Hydra S	To cut off lawn from the sprinkler housing		RT14444

5 Commissioning / Preparing for winter

5.1 Commissioning

- a) Check electrical function:
Before opening water supply to the sprinkler, activate coil via the control module. The sound of a 'click' on the coil lets you determine if the sprinkler's electrical function is working correctly (the click is caused by the rotor being activated).
- b) Make sure that 'Manual opening' is set to AUTO (**turn screw for 'Manual opening' round to the left as far as it will go**).
On this setting, whenever it is not switched on the sprinkler is guaranteed to close following the supply of water.
- c) Slowly open water supply to the valve until operating pressure is present. The sprinkler may briefly open but should then close automatically after no more than 30 seconds.
- d) Once the water supply is open and the maximum operating pressure has been reached, check sprinkler and connection for leaks.
- e) Check sprinkler is working flawlessly:
Open sprinkler using 'Manual opening' by turning the screw for 'Manual opening' to the position between AUTO and OFF (approx. 1 revolution). Sprinkler head rises and begins to rotate.



Do not stand facing the nozzle opening!

Set desired output pressure by turning the 'Pressure regulator screw' to the right (-) as far as it will go (minimum pressure). The output pressure is now set to approximately 3 bar. If you turn the 'Pressure regulator screw' one complete revolution to the left (+), the output pressure will go up by 1 bar.

- f) Close 'Manual opening' and put in the AUTO position (see point 5b).
Sprinkler should stop the throughflow of water within 30 seconds.
- g) Perform steps e) and f) again repeatedly until this functions are flawlessly.
- h) Check again that the sprinkler is working correctly by starting it electrically from the control module.

5.2 Preparing for winter

Before the onset of any winter frosts, the sprinkler needs to be emptied. To do this, a powerful compressor needs to be attached to the pipeline network. Then open the valve on the sprinkler and keep it open until nothing but air comes out of the nozzle.



The blow out pressure should not exceed 5 bar.

- ☆ Electrically activate the solenoid several times so that any residual water is pushed out of the coil cavity.
During winter time it is recommended to activate the solenoid for about 1 minute 2 times per week.



This model does **not** have a discharge valve and can therefore not be emptied the traditional way by gravity.

6 Setting irrigation sector (Part-circle sprinklers only)



- ☆ Set the left side stop position using:

Left stop position can be adjusted by +/- 90°

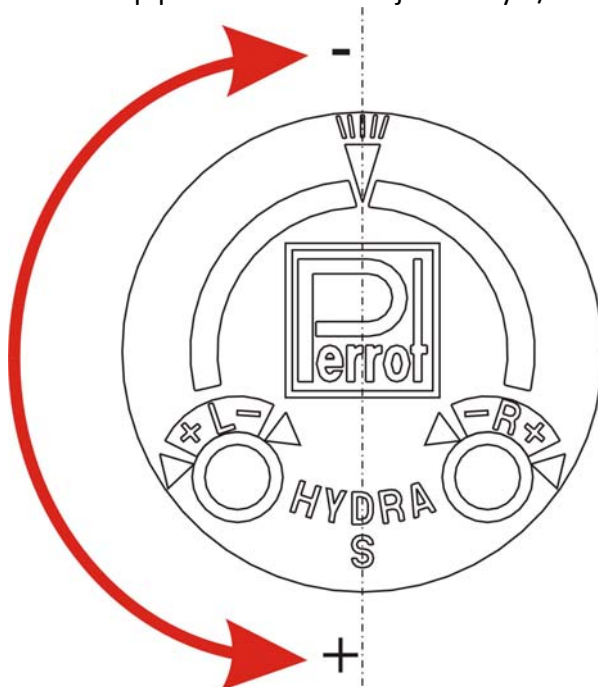

Note:

One complete revolution of the adjuster screw adjusts the sector stop position by 60°



☆ Set right side stop position using:

Right stop position can be set to a watering sector of 30° to 330°.

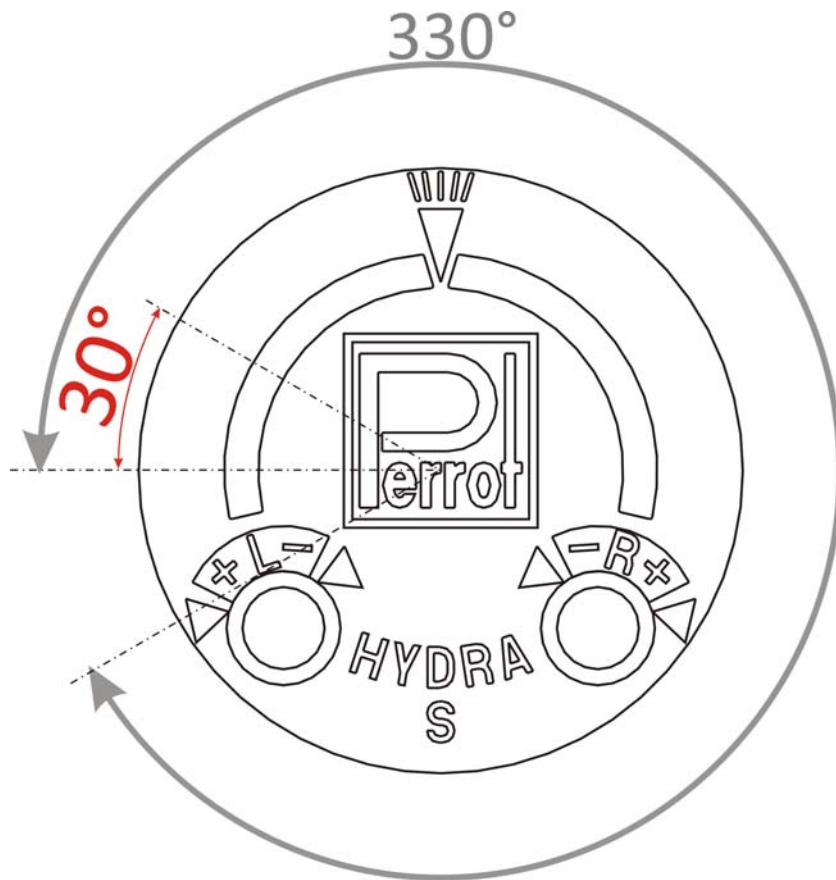

Note: The sprinkler has a factory setting of 180°



Note:

In order to speed up the setting of the irrigation sector, the sprinkler head can be manually turned forward with the rotating direction.



DO NOT TURN BACK!

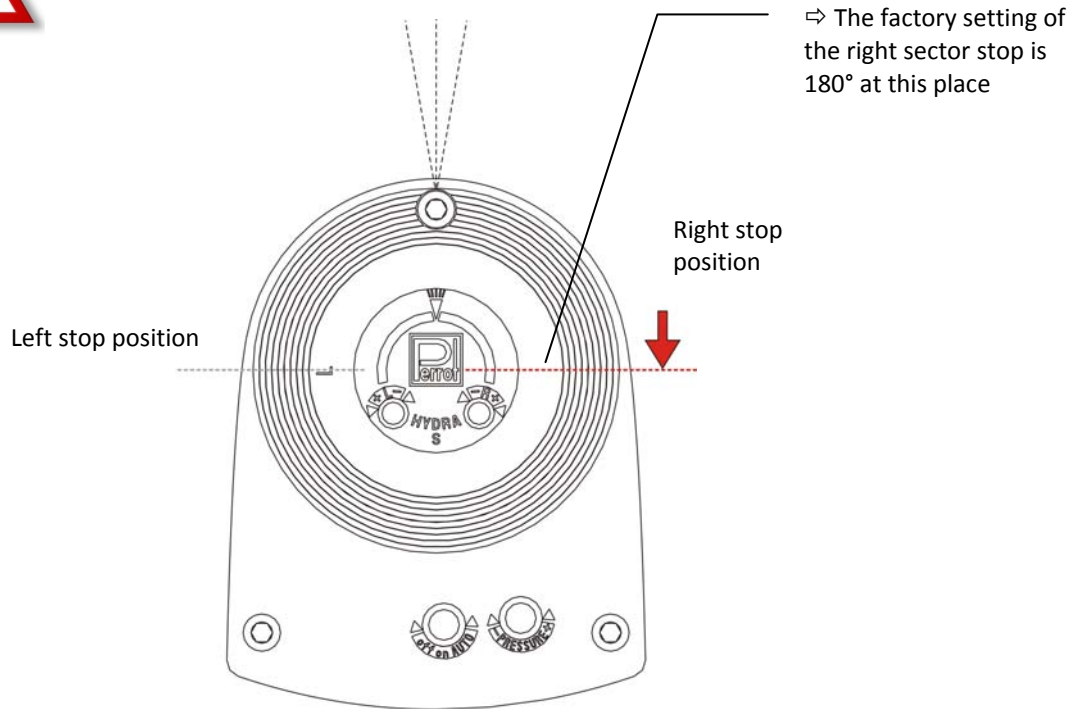

7 Replacing the nozzle



Ensure sprinkler is not under pressure.

- ☆ Loosen all 3 of the cover's securing screws and remove cover.
- ☆ Using a screwdriver, remove white retaining ring.

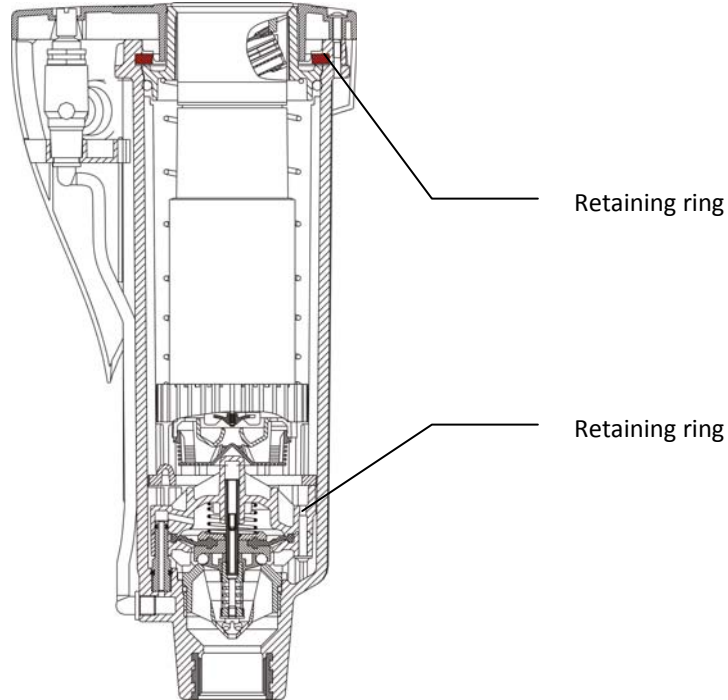

- ☆ Pull sprinkler insert out of the housing
- ☆ Push down the flange and secure the head with the retainer



- ☆ Take off sprinkler head cover by levering the cover up at the notch using a small screwdriver.

- ☆ Rotate nozzle to the left using pliers and then pull out.
- ☆ **Optionally** the sprinkler can be assembled with a tail nozzle. This nozzle can be refitted or/and also closed with a corresponding plug.
- ☆ Put O-ring over the new nozzle

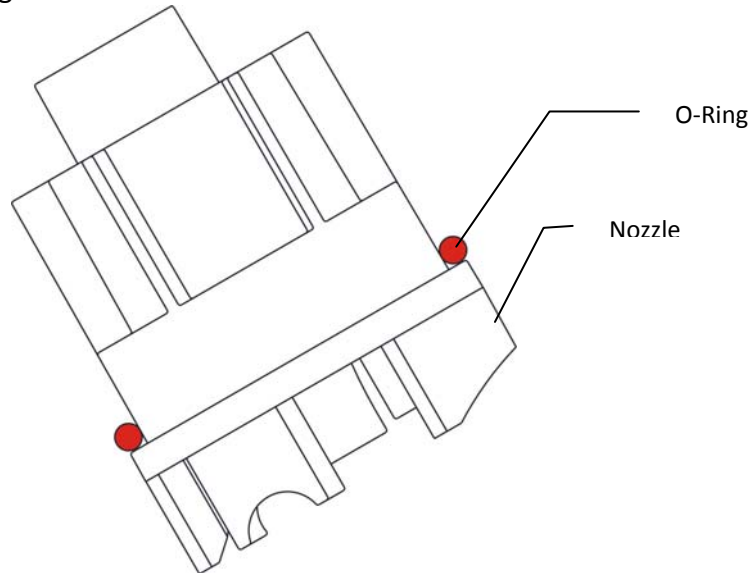

and, reversing the procedure, re-install in the sprinkler head.

- ☆ Fit cover into sprinkler head's snap-in connection by first pushing it as far as it will go against the side opposite the nozzle and then snapping it completely into place on the nozzle side.

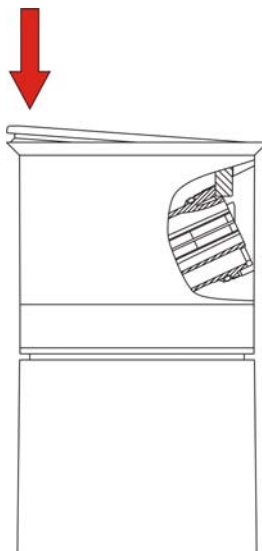

7.1 Adjusting the inlet nozzle

The recommended rotational speed is maintained by correctly adjusting the inlet nozzle.

Adjust as follows:

- ☆ Take off inlet nozzle and filter together by using a screwdriver to lever up the inlet nozzle at the notch.
- ☆ Snap inlet nozzle back onto the sprinkler module so that the elongated rib is pointing to the nozzle diameter being used.



Inlet nozzle

white	for Hydra XS Ø4
black	for Hydra S + Hydra XS Ø5+Ø6
red	for Hydra M

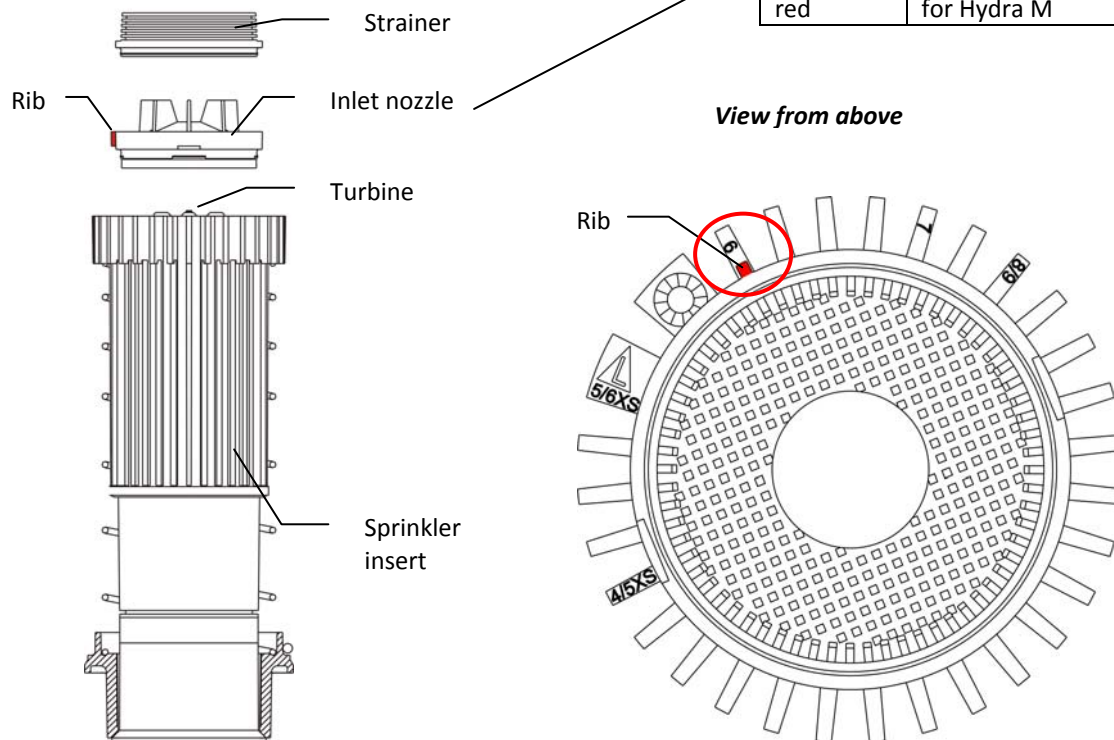

Note:

If you want a higher rotational speed, the rib must be pointing to a smaller diameter than that of the nozzle actually being used.

7.2 Fitting the sprinkler insert

- ☆ Fit O-ring onto flange and lightly grease for easier assembly.
- ☆ Fit sprinkler module inside housing.

WARNING Ensure correct alignment.

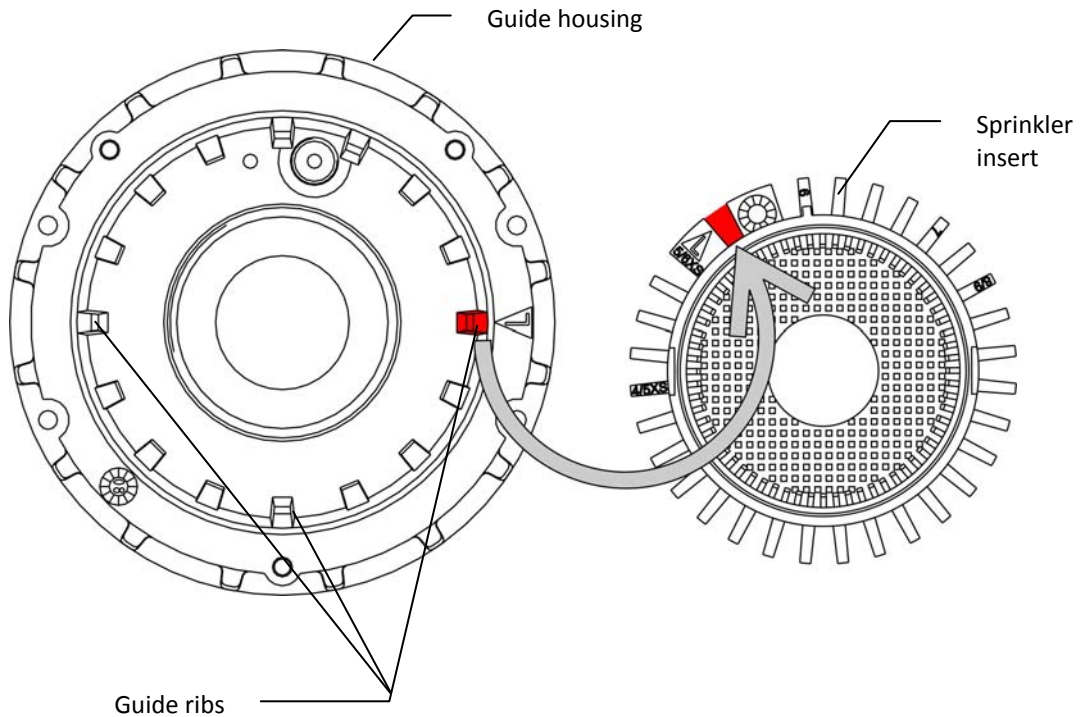

- ☆ Push flange down as far as it will go.
- ☆ Fit retaining ring.

WARNING Retaining ring must be fully inserted into the slot.

- ☆ Secure housing cover using all three screws.
- ☆ Check sprinkler is working properly as per points 5b-5f.

8 Valve insert removal / installation



Ensure sprinkler is not under pressure.

- ☆ Loosen all 3 cover securing screws and remove cover
- ☆ Using a screwdriver, remove white retaining ring

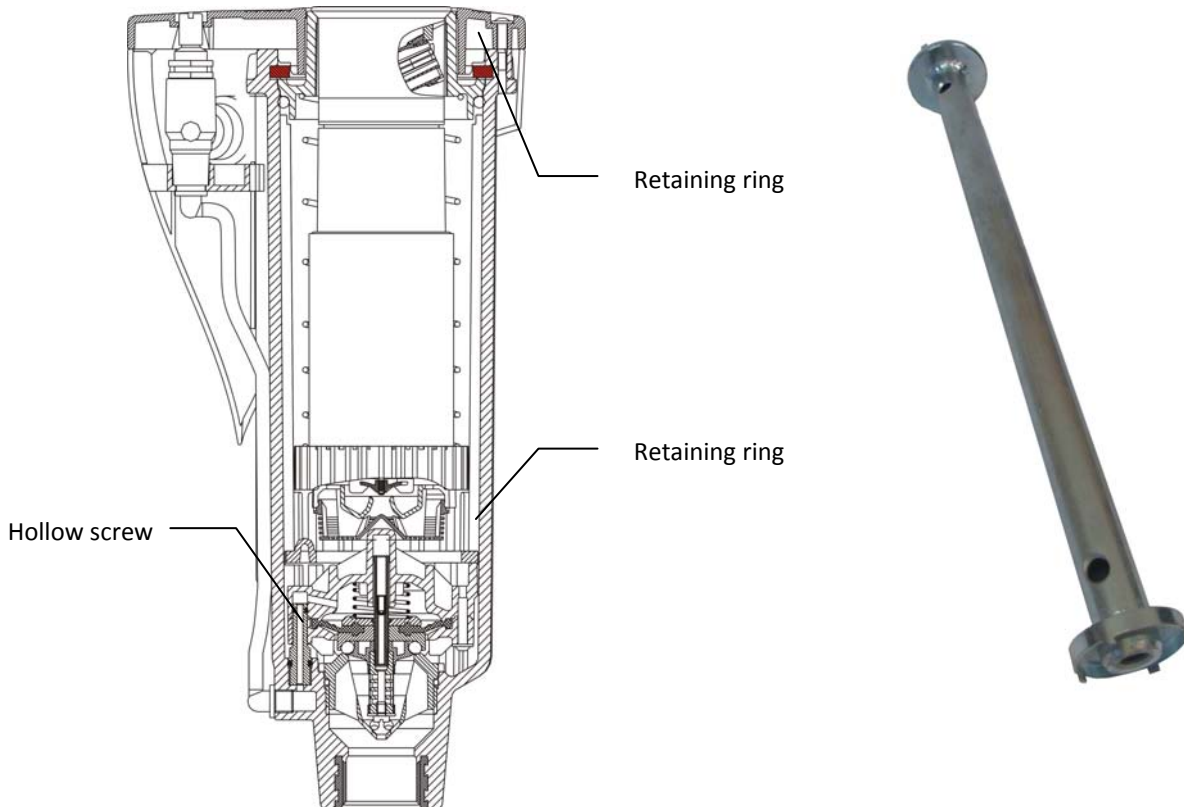

- ☆ Pull sprinkler insert out of the housing

8.1 Taking out the valve

- ☆ Take off retaining ring by help of retaining ring lifter (see chapter 4).
- ☆ Screw valve lifter / coarse filter wrench onto valve insert's studs and manually tighten.
- ☆ Pull out valve insert complete with valve lifter and unscrew. Valve insert is now held on hollow screw by O-ring only.

8.2 Taking out the coarse filter – only if seen to be dirty

- ☆ Insert valve lifter / coarse filter wrench into the filter's slots, turn and pull out.
- ☆ Install flushing equipment and fix it by the retaining ring.
- ☆ Flush sprinkler.

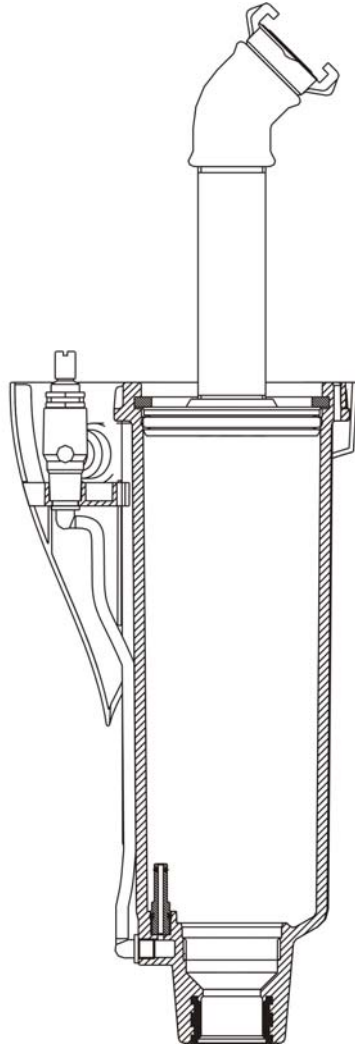

8.3 Fitting coarse filter

- ☆ Twist out flush insert.
- ☆ Ensure that thread and O-ring are clean.
- ☆ Lightly smear O-ring with acid-free grease.
- ☆ Put coarse filter in place and manually tighten using coarse filter wrench.

8.4 Fitting the valve



Before fitting the valve, check the valve insert – especially around the valve seat – for any dirt or damage!

- ☆ Screw cleaned or new valve insert onto the valve lifter again and fit into the sprinkler housing.

WARNING Ensure it is fitted in the correct position!

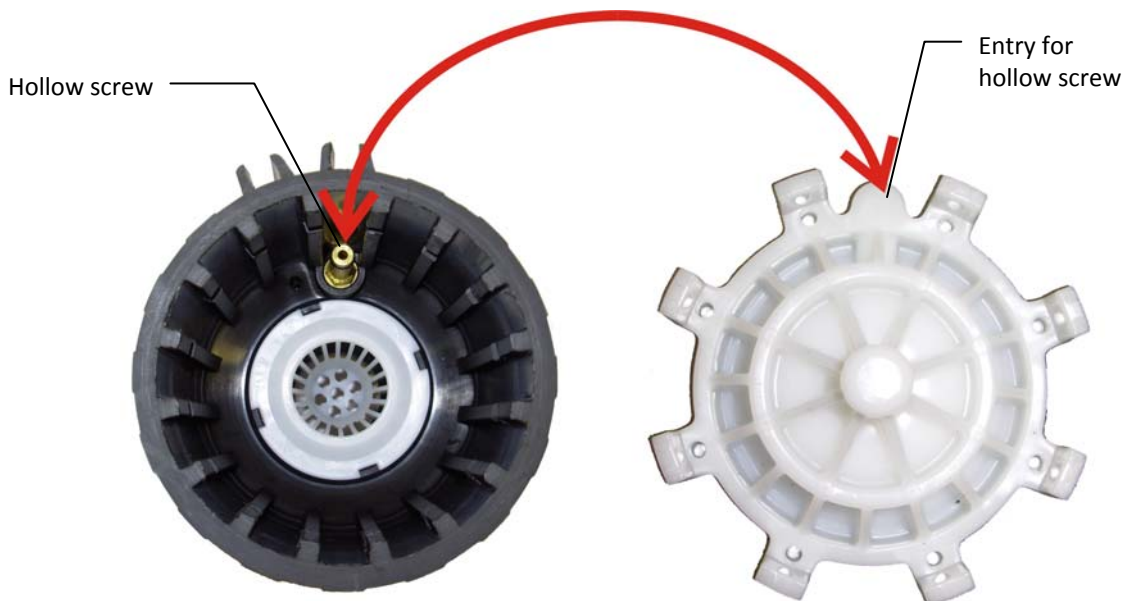

- ☆ Insert retaining ring by help of retaining ring collet (see chapter 4).

WARNING Retaining ring must be fully inserted into the slots!



8.5 Fitting the sprinkler insert

- ☆ Fit O-ring onto flange and lightly grease for easier assembly.
- ☆ Install sprinkler insert inside housing.

WARNING Ensure it is fitted correctly aligned!

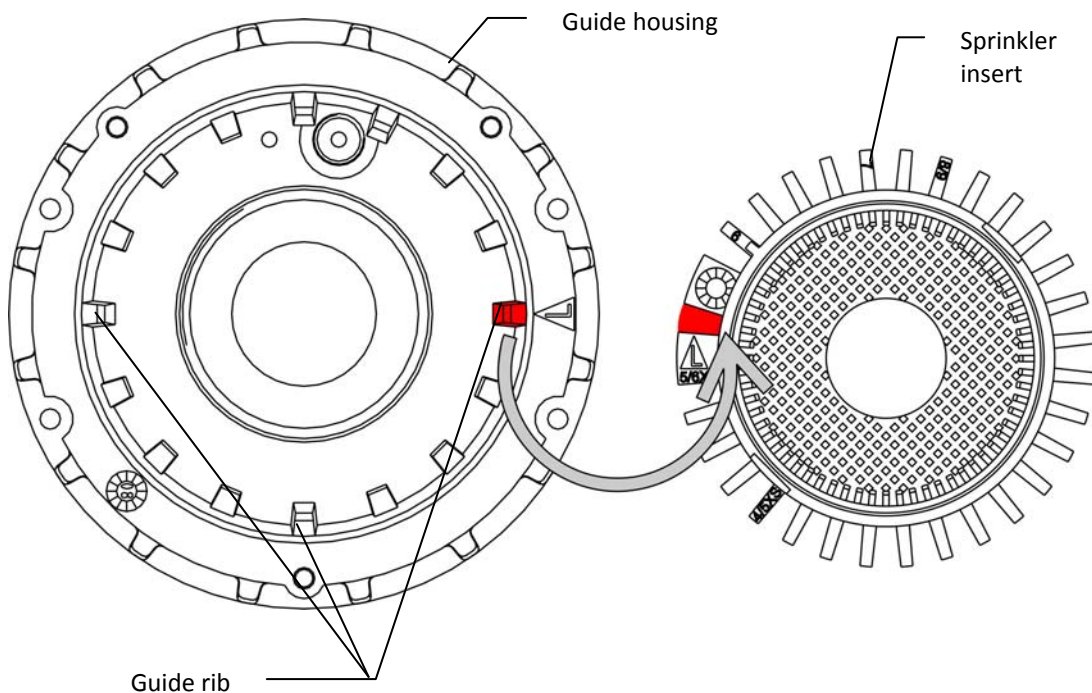

- ☆ Push flange down as far as it will go.
- ☆ Fit retaining ring.

WARNING Retaining ring must be fully inserted into the slot.

- ☆ Secure housing cover using all three screws.
- ☆ Check sprinkler is working properly as per points 5.1b – 5.1f.

9 Control unit removal / installation



Ensure sprinkler is not under pressure.

9.1 Taking out the control unit

- ☆ Loosen all 3 cover-securing screws and remove cover.
- ☆ Unclip control unit from protective casing and lift up.
- ☆ Twist out coil.
- ☆ When replacing the control unit, cut off the hoses as close as possible to the unit's nozzle.



9.2 Fitting the control unit

- ☆ When buying a replacement, the control unit is supplied with plug-and-socket connections. Push hoses into plug-in nozzles as far as they will go and ensure that the mounting ring springs back

WARNING

Please ensure that the hoses are fitted in the correct position. Otherwise the sprinkler will not work.

- ☆ Screw in coil.
- ☆ Clip control unit into protective casing.
- ☆ Secure housing cover using all three screws.
- ☆ Check sprinkler is working properly as per points 5b – 5f.

10 Removal / fitting of manual opening and pressure regulating inserts



Ensure sprinkler is not under pressure.

10.1 Removal of manual opening and pressure regulating inserts

- ☆ Loosen all 3 cover-securing screws and remove cover.
- ☆ Unclip control unit from protective casing and lift up.
- ☆ Using an SW19 flat spanner, twist out manual opening and pressure regulator screws.

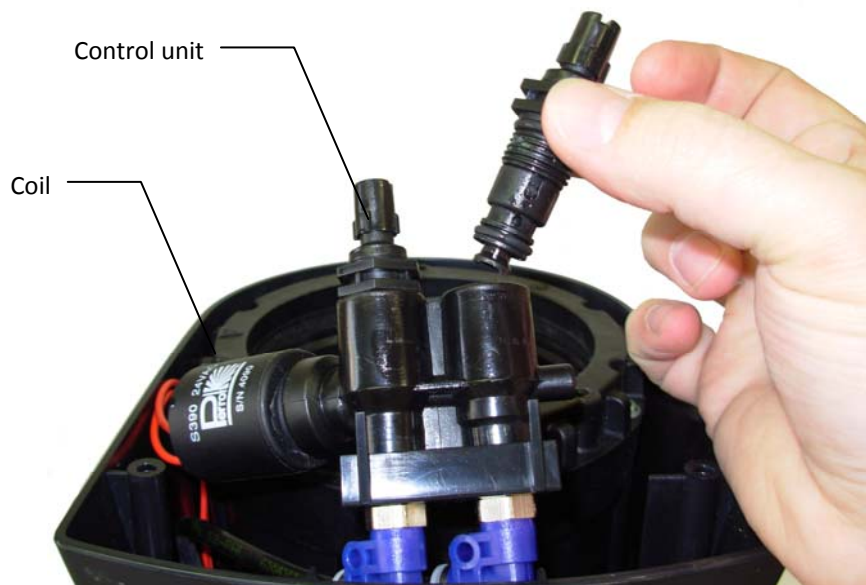



10.2 Fitting manual opening and pressure regulating inserts

- ☆ Set manual opening to Auto and pressure regulator into the minus (-) position (turn to the left as far as it will go) and screw in using an SW19 flat spanner.
- ☆ Clip control unit into protective casing.
- ☆ Secure housing cover using all three screws.
- ☆ Check sprinkler is working properly as per points 5.1b – 5.1f.
- ☆ Set manual opening / pressure regulator screws to desired position.

11 Maintenance

- ☆ Cut sprinkler housing free of any overgrowing grass. It makes sense to do this work with the cut off tool (see chapter 4 for the order number) before starting up the system in spring.

12 Troubleshooting

12.1 Malfunctions

Problem	Cause	Remedy
Valve opens/closes only with manual opening, but not on any electric signal	Screw for 'Manual opening' is set to OFF	Turn screw to the left as far as it will go
	Core is jammed in the coil	Take out coil and clean core
	No / inadequate power supply	Establish 24V AC power supply
	Coil defective	Check coil resistance (should be ca. 35 ohms) and replace if necessary
	Overflow channel from coil clogged	Clean channel
Valve fails to open even with manual opening	Control water hole or relief hole clogged	Clean control water / relief hole
	Feeder pipeline under no / insufficient pressure	Establish pressure supply
Valve fails to close	Coil seat dirty	Clean coil seat
	Bits of dirt between valve seat and sealing plate	Clean valve seat and sealing plate
	Diaphragm defective	Take out valve and replace diaphragm
	Insufficient drop in pressure at the valve	Tighten 'pressure regulator screw'
	Control water filter dirty	Clean control water filter
Rotary speed too low / too high or does not rotate at all	Inlet nozzle incorrectly set (see chapter 7)	Set inlet nozzle to correct nozzle diameter
	Turbine blocked by stones or bits of dirt	Clean turbine
	Inlet nozzle or filter have worked loose	Clip parts together again
Output pressure at sprinkler nozzle too low or casting range too short	Stones and bits of dirt are hindering an unimpeded flow-through of water	Clean valve and flush sprinkler
	Pressure regulator in minus (-) position	Turn pressure regulator screw to the left towards (+)

Subject to change without prior notice.